

COUNTRY ROADS BOARD

VICTORIA



# **SIXTY-FIRST ANNUAL REPORT**

FOR YEAR ENDED 30th JUNE, 1974

PRESENTED TO BOTH HOUSES OF PARLIAMENT  
PURSUANT TO ACT No. 6229

## COUNTRY ROADS BOARD

<i>Chairman</i> . . . . .	<b>R. E. V. Donaldson</b>
<i>Deputy Chairman</i> . . . . .	<b>J. D. Thorpe</b>
<i>Member</i> . . . . .	<b>T. H. Russell</b>

### PRINCIPAL OFFICERS AS AT 30th JUNE, 1974 HEAD OFFICE

<i>Chief Engineer</i> . . . . .	<b>W. S. Brake</b>
<i>Secretary</i> . . . . .	<b>N. L. Aflanson</b>
<i>Chief Accountant</i> . . . . .	<b>R. G. Cooper</b>
<i>Deputy Chief Engineer</i> . . . . .	<b>Dr K. G. E. Moody</b>
<i>Deputy Secretary</i> . . . . .	<b>C. C. Liddell</b>
<i>Deputy Chief Accountant</i> . . . . .	<b>R. J. C. Bulman</b>

### REGIONAL DIVISIONAL OFFICES

<i>Division</i>	<i>Divisional Engineer</i>
Bairnsdale . . . . .	<b>A. N. Jephcott</b>
Ballarat . . . . .	<b>E. T. Oppy</b>
Benalla . . . . .	<b>R. R. Patterson</b>
Bendigo . . . . .	<b>T. M. Glazebrook</b>
Dandenong . . . . .	<b>R. W. Angus</b>
Geelong . . . . .	<b>G. W. Marshallsea</b>
Horsham . . . . .	<b>J. W. Heid</b>
Metropolitan . . . . .	<b>L. M. Jones</b>
Traralgon . . . . .	<b>A. Jacka</b>
Warrnambool . . . . .	<b>F. G. Lodge</b>

60 Denmark Street  
Kew  
1st November, 1974

*The Honorable E. R. Meagher, M.B.E., E.D., M.P.*

*Minister of Transport*

*100 Exhibition Street*

*Melbourne 3000*

Sir,

In accordance with the requirements of Section 128 of the Country Roads Act 1958 No. 6229, the Board has the honour to submit to you for presentation to Parliament the report of its proceedings for the year ended 30th June, 1974.

The Board thanks you, Sir, for your support and interest in its activities and wishes to place on record its appreciation of the continued co-operation and assistance of other State Ministers, Government departments, State instrumentalities and municipal councils.

The Board also pays tribute to the continued loyal co-operation and work done by its staff and employees throughout the year.

We have the honour to be,

Sir,

your obedient servants

R. E. V. DONALDSON, A.A.S.A. (Senior),  
A.I.M.A., F.C.I.T., J.P.,  
Chairman

J. D. THORPE, C.E., F.I.E.Aust.,  
F.I.T.E.(U.S.), F.C.I.T.,  
Deputy Chairman

T. H. RUSSELL, M.Eng.Sc., B.C.E.,  
Dip.C.E., C.E., F.I.E.Aust.,  
Member

N. L. ALLANSON, A.A.S.A. (Senior), J.P.,  
Secretary

# CONTENTS

	Page
<b>Review</b>	
Problems of Finance . . . . .	1
Private Motor Vehicle Costs . . . . .	2
Transfer of Road and Bridge Responsibilities of Melbourne and Metropolitan Board of Works . . . . .	3
Construction of Freeways and Dual Carriageway Roads . . . . .	4
Community Involvement in Road Planning . . . . .	7
Metric Signs and Markers . . . . .	7
Traffic Engineering and Road Safety Improvement Programme 1973/74 . . . . .	8
Economics of Road Vehicle Limits Study . . . . .	9
Flood Damage . . . . .	10
Control of Hoardings and Advertising Signs . . . . .	11
<b>Finance</b>	
Receipts . . . . .	12
Expenditure . . . . .	15
Sharing the Cost of Roadworks . . . . .	15
<b>The Declared Road System</b>	
State Highways . . . . .	16
Freeways . . . . .	17
Tourists' Roads . . . . .	18
Forest Roads . . . . .	18
Main Roads . . . . .	19
Unclassified Roads . . . . .	19
<b>Road Construction and Maintenance</b>	
Mulgrave Freeway . . . . .	20
Special Projects . . . . .	21
Land Purchase . . . . .	21
Contracts . . . . .	22
Bituminous Surfacing . . . . .	23
Linemarking . . . . .	24
Roads to Snow Resorts . . . . .	24
Street Lighting . . . . .	25
<b>Bridges</b>	
Construction of New Bridges . . . . .	25
Large Bridges Completed in Rural Areas . . . . .	26
Metropolitan Bridges and Overpasses . . . . .	28
Grade-separated Pedestrian Crossings . . . . .	29
Bridge and Culvert Materials . . . . .	30
<b>Elimination of Railway Level Crossings</b>	30
<b>Transportation Studies</b>	31
<b>National Parks Roads</b>	33
<b>Roads of Tourist Interest</b>	33
<b>Municipalities Forest Roads Improvement Fund</b>	33
<b>Control of Heavy Traffic</b>	34
<b>Legislation Affecting the Board</b>	34
<b>Thirtieth Conference of Municipal Engineers</b>	36
<b>Australian Road Research Board</b>	36
<b>Visits to Municipalities</b>	37
<b>Deputations</b>	37
<b>National Association of Australian State Road Authorities</b>	37
<b>Co-operation with Army Reserve (C.M.F.)</b>	38
<b>Personnel</b>	39
<b>Films, Photography and Displays</b>	41
<b>Appendix 1</b> — Mileages of State Highways, Freeways, Forest Roads, and Tourists' Roads . . . . .	42
<b>Appendix 2</b> — State Highways and Freeways . . . . .	44
<b>Appendix 3</b> — Tourists' Roads and Forest Roads . . . . .	50
<b>Appendix 4</b> — Main Roads . . . . .	52
<b>Appendix 5</b> — Unclassified Roads . . . . .	58
<b>Appendix 6</b> — Special Projects . . . . .	63
<b>Appendix 7</b> — Motor Registrations . . . . .	64
<b>Appendix 8</b> — Statement of Receipts and Payments . . . . .	65
<b>Appendix 9</b> — Loan Liability . . . . .	66
<b>Appendix 10</b> — Works Executed on behalf of other Government Authorities . . . . .	67
<b>Appendix 11</b> — Chief Engineer's Report . . . . .	69

**Cover:**

<i>The Mornington Peninsula Freeway at McCrae</i>	<i>The Frankston Freeway</i>
<i>The Princes Highway West at West Footscray</i>	<i>Bridge over the Mitta Mitta River on the Dartmouth Road</i>

**During 1973/74 the Board:**

- **Expended \$92,549,000 on new roads and bridges and the maintenance and improvement of existing roads and bridges.**
- **Expended \$11,706,000 on the purchase of land for road purposes.**
- **Constructed 21 miles of additional dual carriageways.**
- ⊙ **Sealed or resealed with bitumen 2,942 miles of road.**
- **Commenced the construction of 143 new bridges.**
- **Planted 80,000 trees and shrubs on road reserves.**
- **Allocated \$50,684,000 for expenditure by municipalities on main and unclassified roads.**

# ANNUAL REPORT 1973/74

## REVIEW

### PROBLEMS OF FINANCE

The Board's Annual Report for financial year 1972/73 referred to the fact that much needed construction and reconstruction work on Victoria's principal road system had to be deferred because the level of funds available had fallen drastically short of current needs.

During the financial year 1973/74, inflationary trends further reduced the amount of work which could be carried out for each dollar available to the Board. Indeed inflation in the road construction industry exceeded 20% during the financial year.

#### C.R.B. EXPENDITURE<sup>(1)</sup> 1966/67-1973/74 TOTAL EXPENDITURE AND EXPENDITURE PER MOTOR VEHICLE EXPRESSED IN 1966/67 VALUES

Financial Year	Actual Expenditure	Real Expenditure (2)	Index of Real Expenditure	Number of Motor Vehicles on Victorian Register (3)	Real Expenditure Per Motor Vehicle	Index of Real Expenditure Per Motor Vehicle
	\$'000	\$'000		'000	\$	
1966/67	67,575	67,575	100.0	1,119	60.39	100.0
1967/68	72,443	69,213	102.4	1,174	58.95	97.6
1968/69	77,452	68,828	101.9	1,231	55.91	92.6
1969/70	87,115	73,702	109.1	1,295	56.91	94.2
1970/71	95,838	73,922	109.4	1,353	54.64	90.5
1971/72	99,685	71,031	105.1	1,407	50.48	83.6
1972/73	103,488	65,812	97.4	1,476	44.58	73.8
1973/74	115,741	60,219	89.1	1,540 (Est.)	39.10	64.7

(1) Includes expenditure on Special Projects charged to Roads (Special Projects) Fund.

(2) Real expenditure is derived by deflation of actual expenditure by changes in ruling end-of-year prices.

(3) Number of motor vehicles on register as at 30th June each year — Commonwealth Series (adjusted for 1971 census results). Excludes motor cycles.

Announcements by the Commonwealth Government of the expected level of Commonwealth grants for roads in financial years 1974/75, 1975/76 and 1976/77 are much less than the amounts recommended by the Commonwealth Bureau of Roads following a comprehensive road needs survey carried out by State Road Authorities in conjunction with the Commonwealth Bureau of Roads. The Bureau had recommended that Victoria should receive \$293 million for expenditure on roads over the next three financial years whereas the Commonwealth Government is prepared to provide only \$232 million. The difference of \$61 million is all the more marked by the fact that the Commonwealth Bureau of Roads' recommended level of grants only allowed for an inflationary factor of 6% per annum instead of at least 20% per annum. After allowing for inflation of only 20% per annum in future the Commonwealth funds to be made available from 1st July 1974 to 30th June 1977 will be 18.6% less than those received over the preceding three years in terms of real financial capacity to perform works.

The inadequate level of funds to be made available by the Commonwealth to Victoria caused the Board to recommend to the Government during the latter part of the financial year that a large increase in motor registration fees be approved from 1st January 1975, the full amount of the additional revenue received to be paid into the Country Roads Board Fund without any further statutory charges or imposts being made against the Country Roads Board Fund.

In view of the inadequate level of the proposed Commonwealth road grants, road programmes would have to be cut and municipal and Board's direct labour forces substantially reduced unless the proposed increase in motor registration fees is received.

### Roads (Special Projects) Fund

The Roads (Special Projects) Fund was established on 1st July 1965 and the total amount paid into the fund to 30th June 1974 was approximately \$120 million. Moneys paid into the fund represent approximately 31.5% of the revenue received from motor registration fees.

In accordance with an undertaking given in May 1965 by the then Hon. the Premier, approximately two-thirds of the moneys paid into the fund are being expended on projects in the Melbourne Metropolitan Planning Area and one-third outside this area.



In general the special projects in the Melbourne Metropolitan Planning Area have been carried out by the Melbourne and Metropolitan Board of Works. With the transfer of the Melbourne and Metropolitan Board of Works roading responsibilities to this Board, the full amount of the Roads (Special Projects) Fund will be expended by this Board.

Adherence to the terms of the Hon. the Premier's statement made in 1965 has in recent years introduced a difficulty in obtaining a desirable degree of flexibility in the use of funds available to the Board, especially when considered in conjunction with the specified categories of roads and works on which Commonwealth funds may be expended.

In order to assist the flexibility of the Board's financial programming and financial management, the Board recommended during the year that the administrative requirement that two-thirds of the expenditure from the fund be expended in the Melbourne Metropolitan Planning Area be dispensed with. In addition the Board recommended that consideration be given to the drafting of legislation to enable the revenue at present paid into the Roads (Special Projects) Fund to be credited to the Country Roads Board Fund.

## PRIVATE MOTOR VEHICLE COSTS

During the year an analysis was made of the costs of owning and operating a popular Australian made medium sized six-cylinder motor car. The calculations on which the analysis was based assumed that the car was bought new in Victoria in June 1974, and operated for 100,000 miles during a period of ten years. All tax rates and prices were assumed to remain constant for the period of the analysis at the rates applying in June 1974.

The detailed estimates of costs per vehicle mile of travel are set out in the table below:

### COSTS OF OWNING AND OPERATING A MOTOR CAR FOR TEN YEARS (TOTAL VEHICLE MILES = 100,000)

	Costs in cents per vehicle mile					
	Total Cost	Total excluding Taxes	Taxes		Amount of Taxes Returned to Roads	
			Common-wealth	State	Common-wealth	State
Registration Fees	0.34	—	—	0.34		0.325
Driver's Licence Fee	0.04	—	—	0.04		0.005
Compulsory Third Party Insurance	0.65	0.60	—	0.05		—
Comprehensive Insurance (incl. 7% Stamp Duty)	0.835	0.78	—	0.055		—
Maintenance (repairs, oil, tyres, etc.)						
Labour (incl. 4½% payroll tax)	0.835	0.80	—	0.035		—
Parts, etc. (incl. 15% sales tax)	0.765	0.665	0.10	—		—
Petrol (incl. 22.3 cents/gal. tax)	2.63	1.63	1.00	—	} 0.43	—
Depreciation (purchase price \$3,580 including 27½% Sales Tax) using 22½% diminishing value	3.30	2.53	0.77	—		
Stamp Duty on purchase (\$4 per \$200)	0.07	—	—	0.07		—
Dealer's delivery charge	0.05	0.05	—	—		—
Interest on outlay	1.21	1.21	—	—		—
<b>Totals</b>	<b>10.72</b>	<b>8.26</b>	<b>1.87</b>	<b>0.59</b>	<b>0.43</b>	<b>0.33</b>

Of the total cost of 10.72 cents per mile, the largest element (42.1%) is depreciation on the value of the vehicle and the loss of interest on the money invested in the vehicle. Operating costs make up 39.4% of the total. Stamp duty on purchase and delivery charges account for 1.1% and insurances for 13.8%. The remaining 3.6% represents registration and driver's licence fees. It is notable that the last item is a major source of funds raised by the State and directed to roads — 3.6 cents in every dollar of the total outlay.

Of the total cost, the Commonwealth and State Governments receive nearly 23% in taxes and fees of various kinds. The Commonwealth Government returns to the State for use in roadworks only about 4% of the motorist's total cost, and only 23% of the amount taken by the Commonwealth in taxation.

It is apparent from this analysis that even a substantial proportional increase in registration fees, the main source of State funds for maintaining and improving the road system, would cause only a marginal increase in the total cost of travel paid by the motorist. For example, a 60% increase in motor registration fees would increase the motorist's total costs from 10.72 cents to 10.92 cents per vehicle mile, an increase of slightly more than 1.9%. Such a modest increase in the immediate future in the total costs of motoring would enable the Board to effect a large programme of road improvements, which because of the resultant reduced running costs and fewer accidents would, over a period of years, more than compensate motorists for increased annual registration fees.



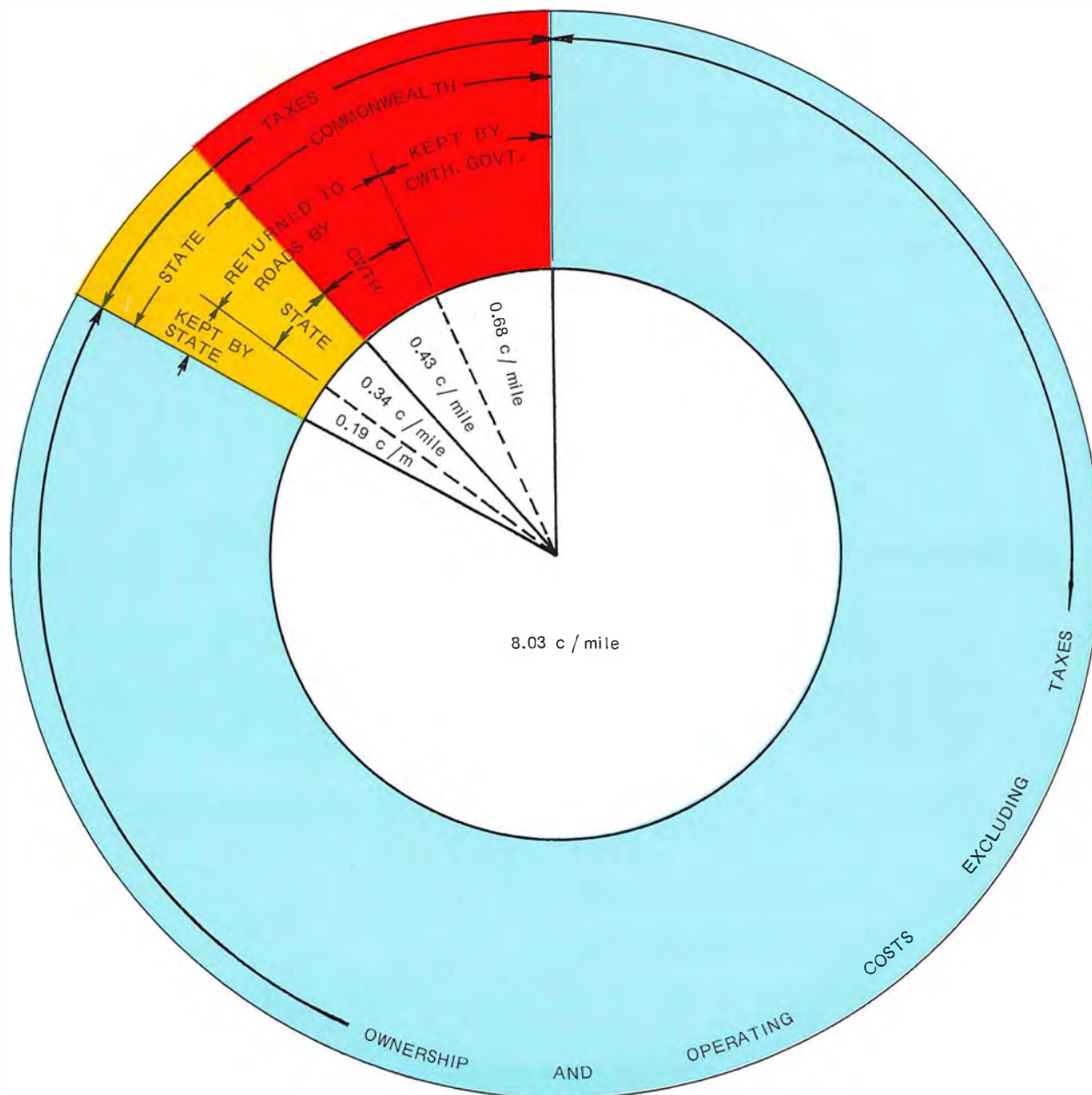

THE TAXATION ELEMENT OF THE COST OF OWNING AND OPERATING A PRIVATE MOTOR CAR IN VICTORIA FOR FOUR YEARS, FROM THE FOURTH TO THE SEVENTH YEAR OF THE VEHICLE LIFE (TOTAL VEHICLE MILES - 40,000) AVERAGE COST PER MILE - 9.67 CENTS

### TRANSFER OF ROAD AND BRIDGE RESPONSIBILITIES OF MELBOURNE AND METROPOLITAN BOARD OF WORKS

In December 1973 the Hon. R. J. Hamer, E.D., M.P., Premier of Victoria, announced that as from 1st July 1974 the responsibilities of the Melbourne and Metropolitan Board of Works for the design and construction of arterial roads and bridges in the Melbourne metropolitan area would be transferred to the Country Roads Board.

Amending legislation was required to give effect to the transfer and the Metropolitan Bridges Highways and Foreshores Act 1974 was enacted in the first week of May 1974. The provisions of this Act are explained in detail on page 34 of this report.

The transfer of the responsibilities from the Melbourne and Metropolitan Board of Works on 1st July 1974 entailed detailed co-ordination between both Boards at many levels. Matters relating to the transfer of staff, land, contracts, finance, roads and other assets and liabilities involved detailed co-operation between the two Boards. The Board desires to record its appreciation of the co-operation received from the Chairman and officers of the Melbourne and Metropolitan Board of Works in this regard.

A total of 213 personnel were included in the revised list of personnel required in accordance with the Act to be prepared by the Melbourne and Metropolitan Board of Works as at 30th June 1974 for transfer to the Country Roads Board.

The Board appreciates the skills, knowledge and experience of the personnel transferring from the Melbourne and Metropolitan Board of Works and looks forward to their efficient integration into the Board's organization.

The additional declared roads which will become the direct responsibility of the Country Roads Board as a result of the transfer of responsibilities on 1st July 1974 are as follows:—

The Tullamarine Freeway from Flemington Bridge to Bell Street.  
The South Eastern Freeway.  
Kingsway/Queens Road/St. Kilda Junction and Queensway.  
St. Kilda Road underpass (Alexandra Avenue).  
High Street, St. Kilda (under construction).  
The Eastern Freeway (under construction).

## **CONSTRUCTION OF FREEWAYS AND DUAL CARRIAGEWAY ROADS**

Although the Board's construction programme was severely hampered because of limited finance and in some cases by the supply of materials the Board completed the construction of 17.36 miles of dual carriageways on freeways and State highways. Approximately 3.9 miles of declared main roads were also converted to dual carriageways by municipal councils with financial assistance from the Board. This increased the total mileage of dual carriageways on freeways, State highways, and main roads to 355 miles.

The more important dual carriageway projects completed, in progress or in the planning stage during the year are briefly described below:

### **Mulgrave Freeway and South Gippsland Freeway**

The construction of 3.5 miles of the Mulgrave Freeway and the South Gippsland Freeway from the Princes Highway at Hallam to Stud Road, Dandenong North, was completed in November 1972. A further 4.7 miles of the Mulgrave Freeway from Springvale Road to Stud Road was completed and opened to traffic during the year at a cost of \$9.3 million.

A contract was awarded for the construction of a further 2.1 miles of the Mulgrave Freeway between Springvale Road and Forster Road, Mount Waverley, and for earthworks along the adjoining section to Stanley Avenue, East Oakleigh. Work progressed on this contract, and on bridges to carry local traffic across the freeway at Stanley Avenue and Stephenson's Road.

Between the Princes Highway at Hallam and the South Gippsland Highway at Hampton Park, the South Gippsland Freeway, will provide an additional 1.5 mile extension of the freeway system. Earthworks and bridgeworks, including twin bridges over the Gippsland railway line and the Hallam Main Drain were continued during the year.

### **Hume Freeway (Wallan to Broadford Section)**

Work continued on the construction of the whole length of 21.3 miles of four lane freeway from south of Wallan to north of Broadford. Bridge structures were completed at the Wallan East interchange, Glenelgin interchange, and Arkells Road overpass. The project is expected to be completed in 1976 at an estimated cost in terms of 1973/74 prices of \$21.6 million.

### **Western Freeway (Pentland Hills Section)**

Three miles of the 3.5 mile section of the Western Freeway (Pentland Hills Section) west of Bacchus Marsh were opened to traffic during the year. The remaining 0.5 mile will be completed in conjunction with the adjoining Myrning section of the freeway.

### **Western Freeway (Myrning Section)**

The construction of 3.6 miles of freeway to by-pass the township of Myrning to the south commenced early in the year. Earthworks and drainage progressed, and bridge-works at the Myrning interchange and the Greendale interchange commenced. The Project is expected to be completed during financial year 1974/75 at an estimated cost in terms of 1973/74 prices of \$1.9 million.

### **Calder Freeway**

The extension of the Calder Freeway from The Avenue, Niddrie, to Erebus Street, Keilor East, a distance of 1.3 miles continued during the year. Traffic used some sections of the freeway carriageways, and the freeway is expected to be in full operation in the second half of the 1974 calendar year. The estimated cost of the work is \$3.8 million.



*New section of the Calder Freeway at Keilor East.*

### **Mornington Peninsula Freeway**

When completed the Mornington Peninsula Freeway will extend from the junction with the Frankston Freeway north of Frankston to Canterbury Jetty Road south of Sorrento.

A length of 2.5 miles south-west from the Nepean Highway at Dromana was opened to traffic in 1972. A further 2.5 mile section to Jetty Road, Rosebud, was opened to traffic in December 1973.

### **South Gippsland Highway**

Work commenced on the provision of 5.2 miles of dual carriageway between Hampton Park and Cranbourne. The work is programmed to be completed during 1974/75 at an estimated cost of \$1.8 million.



### **Princes Highway East**

In the township of Yarragon a length of 0.8 mile of dual carriageways was constructed at a cost of \$240,000.



*Dual carriageways on the Princes Highway East through Yarragon.*

### **Bellarine Highway**

Dual carriageways were completed between Moolap and Leopold, a distance of 1.6 miles, at a cost of \$558,000.



*Dual carriageways on the Bellarine Highway between Moolap and Leopold.*

## COMMUNITY INVOLVEMENT IN ROAD PLANNING

Section 15 of the Country Roads Act prescribes that "The Board . . . shall carry out all such surveys and investigations as may be necessary or expedient to ascertain . . . what new roads should in its opinion be made so as to facilitate communication and improve the conditions of traffic."

Such a provision has been part of the Act under which the Board has operated since 1913, and its original inclusion may have been prompted by a need similar in principle, but smaller in extent, to the current need to meet the traffic demands of our highly mobile society.

Transportation studies, which include route feasibility studies and economic evaluations, are useful starting points for establishing a prima facie need for substantial road improvements in urban areas. Supplemented by information regarding such factors as accidents, traffic delays, land development proposals, etc., a conclusion may be reached that the substantial road improvements should be in the form of a length of a new high capacity road.

In the detailed investigations that follow the need for substantial road improvements many concept solutions are considered. These could range from improvements to the existing road system to the construction of a completely new road to full freeway standards. In general, concepts which are not feasible in satisfying community needs are rejected, and those which are inferior in terms of economics or service by comparison with other alternatives are classified as not worthy of closer study. A great deal of factual information is needed to enable such decisions to be made. Data on such matters as social networks, the use of open space and community facilities, areas of unique interest, and public attitudes are often best obtained from municipal councils or from responsible community groups formed by people who have a common interest in the investigations and suggested solutions.

The Board welcomes the opportunity to be represented at meetings convened by municipal councils where road proposals are discussed. During 1973/74 senior officers of the Board attended public meetings at Ringwood and St. Albans which were convened to enable residents to gain a better awareness of particular road proposals and to discuss community problems associated with these proposals.

Several alternative proposals for a solution to road problems in the Ringwood area were studied during the year as a result of an earlier undertaking by the Board that it would evaluate alternatives submitted by interested parties. Suggestions were received from Councils, community groups and interested individuals. These included new routes of full freeway standard which could form part of a much wider freeway network, local by-pass freeways, new arterial roads, widening of existing arterial routes, and alternative transport systems. A "no build" concept was also included to form a basis against which other concepts can be measured. The results of the evaluation will be made available to the Councils and the community early in the 1974/75 financial year, and those concepts which are found to be practicable will be further examined for social and environmental impact by independent consultants engaged by the Board.

Jointly with the Melbourne and Metropolitan Board of Works the Board, during 1972/73, commenced an investigation into the practicability of locating a freeway in the area between Chelsea and Moorabbin. The need for a freeway extending the Mornington Peninsula Freeway corridor generally north-west from Wells Road, Edithvale, had been established by the 1968 Metropolitan Transportation Study. As well as engaging consultants to compile information about communities and facilities in the study area, a Citizen Committee of interested ratepayers was formed as a permanent part of the investigation structure. The Committee provides an avenue for the exchange of information and ideas which has proved to be of mutual benefit to both the Board and the people of the area.

In areas where alternative solutions are restricted, or where the community is not greatly involved or interested, the Board is able to rely on its long established ties with municipal councils and their ability, as elected representatives, to make responsible judgements on behalf of their citizens and ratepayers. During the year the Board or its officers met with a number of councils and their officers to discuss particular roading developments.

## METRIC SIGNS AND MARKERS

Since 1967 formal discussions have been held between representatives of Commonwealth and State governments to consider the possibility of introducing the metric system of weights and measures throughout Australia. In January 1970, the Prime Minister announced the decision to change to the metric system.

The specific task of implementing this change in relation to the road system was to be the responsibility of each State road authority, co-ordinated at a national level through the National Association of Australian State Road Authorities.



In 1972, N.A.A.S.R.A. resolved that the change-over from imperial to metric measures on road signs should commence on 1st July 1974, and if possible to be completed by 1st August 1974. The necessary preparatory work took place prior to 1st July 1974.

Arrangements were made for some signs to be replaced and others to be changed by the use of an overlay depending on the legend of each sign. For example, provision was made for speed limit signs to be replaced because the numerical figures on such signs represent a large proportion of the total sign area. On the other hand, finger board signs showing both distance and township names, only needed conversion of the distance numerals by the attachment of overlays.



*Distance markers to be erected at 5 km spacing.*

The new speed limit signs are similar to those used in Europe, except that they are mounted on a rectangular plate instead of a circular one.

The Board's personnel arranged for the signs to be changed on State highways and roads under the direct supervision of the Board, and municipal councils undertook the necessary conversion of signs on roads under their control.

Two kinds of markers are being used to indicate distances in kilometres. A dark green plate with a white legend showing the initial letter of the datum town and the distance therefrom and having a white reflectorized border is being erected at 5 kilometre spacings. At every intermediate kilometre a white guide post is being erected having a white reflectorized legend on a small black plate near the top of the post. The old mileposts will be retained in their present positions for as long as they are required for reference purposes.

The cost of converting all signs on roads declared or proclaimed under the Country Roads Act will be met by the Board. The cost of converting speed limit signs on all other roads will be met from a special grant made available by the State Government to the Road Safety and Traffic Authority.

#### **TRAFFIC ENGINEERING AND ROAD SAFETY IMPROVEMENT PROGRAMME 1973/74**

Towards the close of the 1972/73 financial year the Commonwealth Government wrote to the State Governments with regard to co-operating in a programme to improve road safety at locations with high accident records.

As a first step the Commonwealth Department of Transport and the Commonwealth Bureau of Roads decided to undertake a national survey to determine what needed to be done at locations with poor accident records. It was necessary for the Commonwealth Government to obtain from Victoria a statement of the locations and the types of improvements considered warranted.

The data required by the Commonwealth Government included details of various types of traffic engineering and road safety improvement projects, together with information regarding the warrants and procedures used. The Board obtained the approval of the State Minister of Transport, The Hon. E. R. Meagher, M.B.E., E.D., M.P., to supply the Commonwealth Bureau of Roads with information on the Board's warrants and practices for works to improve road safety. The Minister asked the Board to act as the co-ordinating authority in the preparation of returns by Victoria.

The Board initiated discussions with the Road Safety and Traffic Authority and the Melbourne and Metropolitan Board of Works with a view to preparing and submitting a co-ordinated programme of works suitable for the application of T.E.R.S.I.P. funds. The Board arranged with these authorities to set up a Working Committee to assess applications received from various road authorities, including municipalities and to make recommendations concerning items to be included in a programme. The Commonwealth indicated that projects should generally cost less than \$20,000 but some projects to \$100,000 might be included. The total estimated cost of the programme submitted by Victoria was \$4.8 million.

The Commonwealth Government decided to make available a total of \$3 million for expenditure in all States during 1973/74 for improvements to accident prone locations. Of this amount Victoria was allotted \$840,000 to be spent on low-cost engineering and road safety improvements throughout the State in accordance with a revised programme agreed to between State and Commonwealth authorities.

\$300,000 was set aside for use by the Road Safety and Traffic Authority in the installation or modification of traffic signals.

\$540,000 was allocated by the Board for works on the various classifications of roads as follows—

(1) Roads which are the direct responsibility of the C.R.B.—

State highways	\$222,840
Tourists' roads	450
Forest roads	200
	\$223,490

(2) Roads under the care and management of municipal councils—

Main roads	\$170,150
Unclassified roads	146,360
	\$316,510

The allocations were made on a non-contributory basis, primarily for works at special locations where high numbers of casualty accidents occur.

Most of the improvements will be implemented in 1974/75, and include channelizations, line marking, traffic signs, and other measures which have proved effective in reducing the number of traffic accidents.

## ECONOMICS OF ROAD VEHICLE LIMITS STUDY

Vehicles operating on the road system are subject to limitations imposed by each State covering—

- the weights which may be carried on various axle types and axle groups
- the total gross vehicle weight, and
- the dimensions of width, height and length relating to the basic vehicle types (bus, truck, semi-trailer and truck trailers).

During the 1972/73 financial year the National Association of Australian State Road Authorities (N.A.A.S.R.A.) decided to undertake an extensive national investigation into the economics of road vehicle limits. The Study commenced in December 1973 and is scheduled for completion in mid-1975. Its objective is to provide a means of determining the most appropriate legal limits for road vehicles which could be applied nationally or in particular regions. The Study will consider all the consequences of varying such limits, so that an optimum balance can be achieved between the advantages to the community from changes in the limits and the full cost to the community of providing for these changes.

A Steering Committee, appointed by N.A.A.S.R.A. is responsible for administering the Study. The Committee comprises representatives from N.A.A.S.R.A., the Australian Road Research Board, the Australian Road Transport Federation, the Bureau of Transport Economics and the Commonwealth Bureau of Roads. The Convener of the Steering Committee is Mr. T. H. Russell, Member, Country Roads Board. The Study is being undertaken by a Study Team under the leadership of Mr. A. J. Fry. The Study



Team includes personnel experienced in transport planning, structures, road pavements, economics and systems analysis. Further assistance is also being obtained from consultants who have been briefed to study particular problems associated with the Study.

It is proposed to evaluate the effects of possible changes to vehicle limits. This involves the identification of existing limits which currently impose restrictions on vehicle design and transport operations. Overseas trends in vehicle types and designs will be considered but the extent of any changes proposed will have regard to the present stage of development of Australia's road system.

Since the commencement of the Study, the major effort has been concentrated on a full assessment of all aspects of the problem. In this time, the concepts and procedures have been developed taking into account all the factors involved in the interaction between vehicle loads, the road system and its environment, and road users.

A brochure describing the purpose and intentions of the Study was published for distribution to representatives of the road transport industry and the general public. The preparation of a detailed report and second brochure entitled "Concepts and Procedures" is in progress. Data collection is proposed during the latter half of 1974, with the evaluation phase being carried out during 1975.

## **FLOOD DAMAGE**

Between August and September 1973, exceptionally heavy rainfall in northern Victoria and East Gippsland caused extensive damage to road pavements and bridges. The necessary expenditure on the restoration of roads and bridges under the Board's direct control was approximately \$1,000,000. On roads under municipal control the estimated expenditure was \$1,685,000.

The State Government provided a special allocation to the Board enabling grants amounting to \$1,546,074 to be made to the councils concerned. Contributions by municipal councils were set at approximately half the usual contributions applicable to allocations made by the Board.

Further flooding occurred over a wide area between October 1973 and January 1974, resulting in the need for restoration works on roads under municipal control, totalling \$299,300. Allocations totalling \$265,130 were made by the Board from special funds made available by the State Government subject to council contributions of \$20,350. Damage to roads under the Board's direct control was estimated at \$293,000, and occurred mainly in Bendigo and Benalla Divisions.

Heavy rain during May 1974 again caused severe flooding in northern Victoria and East Gippsland. At the close of the financial year the extent of the damage and the funds required for restoration works were being ascertained.



*Flood waters across the Hume Highway at Wangaratta during June, 1974.*

Roads in the north of the State were badly affected by rising waters which prevailed for long periods of time due to extended flooding in rivers with catchments in the Great Dividing Range. In these areas State highways such as the Hume, Ovens, Goulburn Valley, Kiewa Valley, Sunraysia and Murray Valley were subject to long periods of inundation and subsequent foundation damage. In some instances it was necessary to allow traffic to use lengths of highways which were partially covered by water. Temporary repairs were effected as floodwaters abated, but much major reconstruction will be required earlier than would have otherwise been necessary because of the damage caused.

In Gippsland the problems were related more directly to the damage caused by fast flowing water. On the Cann Valley Highway several culverts were washed away and extensive batter slips occurred. At the township of Cann River, where the Princes Highway crosses the Cann River, the six-span reinforced concrete bridge was damaged in November 1973, by river water undermining the three central piers. In June 1974, further flooding again caused subsidence of the piers and eroded the eastern bank of the waterway to such an extent that much of the highway formation was lost over a distance of 200 feet. The provision of a new bridge and approaches is being investigated.

## CONTROL OF HOARDINGS AND ADVERTISING SIGNS

For many years the Board has had the power to regulate and prohibit the erection of hoardings and advertisements on or in the vicinity of freeways, State highways, tourists' roads and forest roads declared or proclaimed under the provisions of the Country Roads Act. Until an amendment was made to the Country Roads Act in 1969, the Board's powers in relation to main roads were restricted to hoardings and advertising signs on main roads in shires, as distinct from powers relating to signs in the vicinity of main roads throughout the whole State.

The Board's By-Law No. 19, passed in 1970, consolidates all the Board's previous powers and by-laws relating to advertising signs and gives the Board power to control signs both on and in the vicinity of State highways, main roads, tourists' roads, forest roads and freeways for their entire lengths.

Amongst other things, By-Law No. 19 provides that the Board shall refuse its consent to the erection or construction of a hoarding or to the exhibition of an advertisement on or in the vicinity of a Board's declared or proclaimed road if in the opinion of the Board the hoarding or advertisement would or would be likely to:

- (a) obscure the field of view of a user of such highway, road or freeway or of any other road;
- (b) distract the attention of the driver of a vehicle on such a highway, road or freeway or on any other road;
- (c) injuriously affect the amenities of a public park or reserve;
- (d) disfigure the natural beauty of the landscape;
- (e) be unsightly; or
- (f) in any way be detrimental to the safe use of any such highway, road or freeway or of any other road.

During the year the Board prepared a revised code for dealing with hoardings and advertisements. Copies of the code were issued to all municipal councils to enable uniform control to be exercised on the Board's roads throughout the State.

The Board leaves to municipal councils the control of hoardings and advertisements—

- in the vicinity of State highways, tourists' roads and forest roads *in built-up areas* as designated by the Board
- on and in the vicinity of main roads *in built-up areas* as designated by the Board.

The Board exercises direct control over hoardings and advertisements—

- on and in the vicinity of State highways, tourists' roads, forest roads and main roads *in rural areas*
- on State highways, tourists' roads and forest roads between footpath kerbs where such kerbs exist and between fencelines elsewhere, *in built-up areas* as designated by the Board
- on and in the vicinity of freeways in both built-up areas and rural areas.

Over the years the Board has taken great care to observe the provisions of the code in respect of State highways, tourists' roads, forest roads and freeways in rural areas and has strictly controlled signs in the vicinity of these roads. The Board has also completely prohibited unauthorised signs on road reserves.

Until this financial year it was not possible to make the necessary resources available to systematically commence the implementation of the provisions of the code in relation to declared main roads in rural areas. Advertising signs on the 8,080 miles of declared main roads in rural areas were inspected with a view to initiating action to have signs not complying with the code removed as quickly as possible. In most instances the Board's officers engaged in this work received the co-operation of the owners of the signs. The task is a time consuming one involving detailed discussions with owners of the signs and owners of the land on which the signs are erected. During the year 4,960 miles of main roads were completely cleared of signs which did not comply with the Code.

## FINANCE

After deducting the cost of collecting revenue received under the Motor Car Act, the total funds available for expenditure by the Board during the year, including the allocation from the Roads (Special Projects) Fund, was \$116,573,159.

The funds available were derived from:

State sources	\$59,403,771
Commonwealth sources	55,273,584
Balance brought forward from year 1972/73	1,895,804
Total	<u>\$116,573,159</u>

## RECEIPTS

The Board's receipts were obtained from the following main sources:

1. Fees under the Motor Car Act:
  - (a) Motor registration fees less cost of collection (metropolitan bus registration fees and the specified proportion of registration fees paid to the Roads (Special Projects) Fund are excluded).
  - (b) Two-thirds of additional registration fees, less two-thirds cost of collection, levied on first registration and subsequent changes of ownership.
  - (c) Trailer registration fees less cost of collection other than the amount paid to the Roads (Special Projects) Fund.
  - (d) One-eighth drivers' licence fees less one-eighth cost of collection.
  - (e) Seven-eighths drivers' licence testing fees less seven-eighths cost of collection.
  - (f) One-quarter driving instructors' licence fees less one-quarter cost of collection.
  - (g) Examiners' licence fees (motor car roadworthiness examination) less cost of collection.
  - (h) Fees for the issue of authorized log books less cost of collection.
2. All moneys raised under Part II of the Commercial Goods Vehicles Act (ton mile tax).
3. Municipal contributions to expenditure on declared main roads as provided for in the Country Roads Act.
4. Special Government Grants.
5. Small amounts of loan money.
6. Allocations from the Roads (Special Projects) Fund.
7. Receipts under the Commonwealth Aid Roads Act.



The following table shows the funds available to the Board for the construction and maintenance of roads in 1973/74 compared with 1972/73.

Item	1972/73		1973/74	
	\$	\$	\$	\$
<b>RECEIPTS FROM STATE SOURCES</b>				
Fees under the Motor Car Act less cost of collection	35,427,771		37,537,474	
Less: Payment to				
(a) Interest and Sinking Fund	2,611,805		2,618,683	
(b) Research Grant — Melbourne University	—		4,000	
(c) Traffic Authority Fund	342,956		354,278	
(d) Tourist Fund	685,912		708,555	
(e) Transport Regulation Fund	548,173		584,684	
	<u>31,238,925</u>		<u>33,267,274</u>	
Commercial Goods Vehicles Act	9,744,729		10,358,795	
Municipalities' Contributions	2,182,290		2,135,534	
Loan Funds	400,000		300,000	
Special Grant from State Treasury	1,333,000		568,162	
General Receipts	702,997		860,433	
Allocation from Roads (Special Projects) Fund*	5,675,491		7,643,373	
	<u>51,277,432</u>		<u>55,133,571</u>	
Balance B/Fwd at 1st July	132,127		1,895,804	
<b>Total:</b>	<u><u>51,409,559</u></u>		<u><u>57,029,375</u></u>	
<b>RECEIPTS UNDER COMMONWEALTH AID ROADS ACT 1969</b>				
Urban Arterial Roads	36,170,000		42,950,000	
Less: Amount allocated to Melbourne & Metropolitan Board of Works	7,455,000		10,457,522	
	<u>28,715,000</u>		<u>32,492,478</u>	
Rural Arterial Roads	4,110,000		4,870,000	
Rural Roads other than Arterial Roads	16,100,000		16,910,000	
Planning and Research	860,000		990,000	
<b>Total:</b>	<u><u>49,785,000</u></u>		<u><u>55,262,478</u></u>	
<b>RECEIPTS UNDER COMMONWEALTH GRANTS</b>				
Traffic Engineering and Road Safety			<u>11,106</u>	
<b>Total Funds Available for Expenditure by the Country Roads Board</b>				
	101,194,559		112,302,959	
Less: Expenditure on Planning and Research	1,157,324		1,035,694	
Capital Expenditure (Plant, Workshops, Offices, etc.)	2,406,574		1,680,563	
Salaries, Operating A/cs and Other Admin. Expend.	12,123,433		16,206,533	
	<u>15,687,331</u>		<u>18,922,790</u>	
<b>Funds available to the Country Roads Board for Construction and Maintenance of Roads and Bridges</b>	<u><u>\$85,507,228</u></u>		<u><u>\$93,380,169</u></u>	

\*During the period from 1965/66 to 1973/74 one-third only of the receipts paid into this fund were allocated to the Country Roads Board. Two-thirds of these receipts were allocated to the Melbourne and Metropolitan Board of Works.

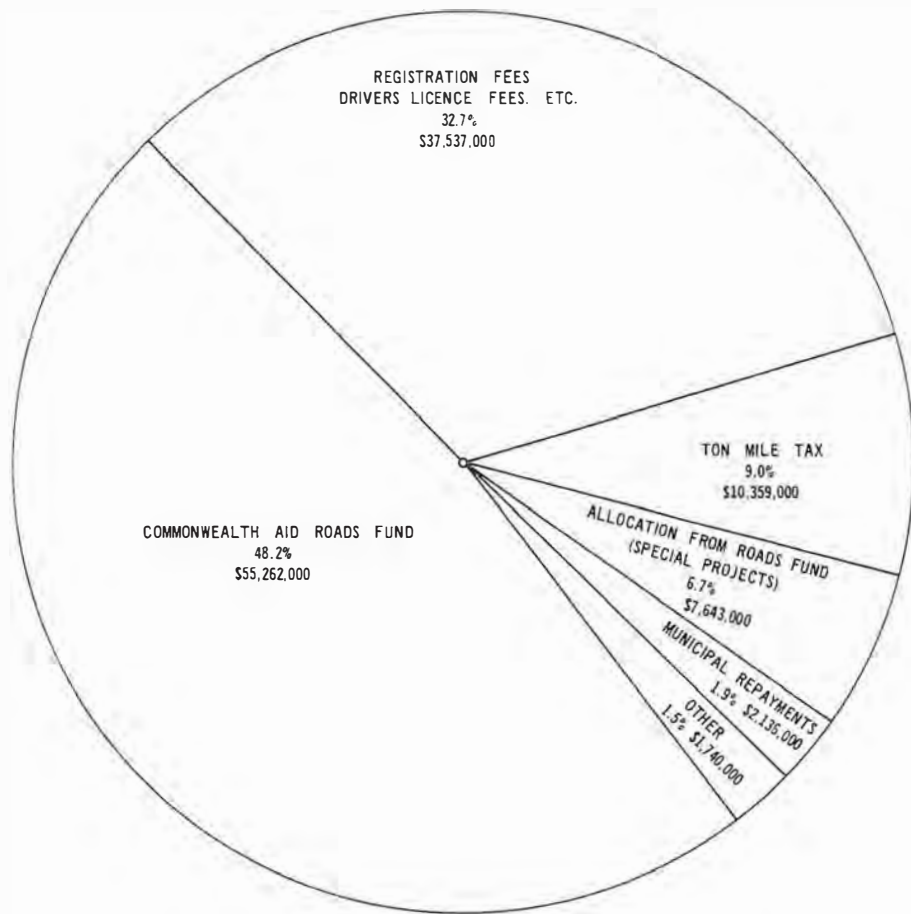

RECEIPTS 1973-74

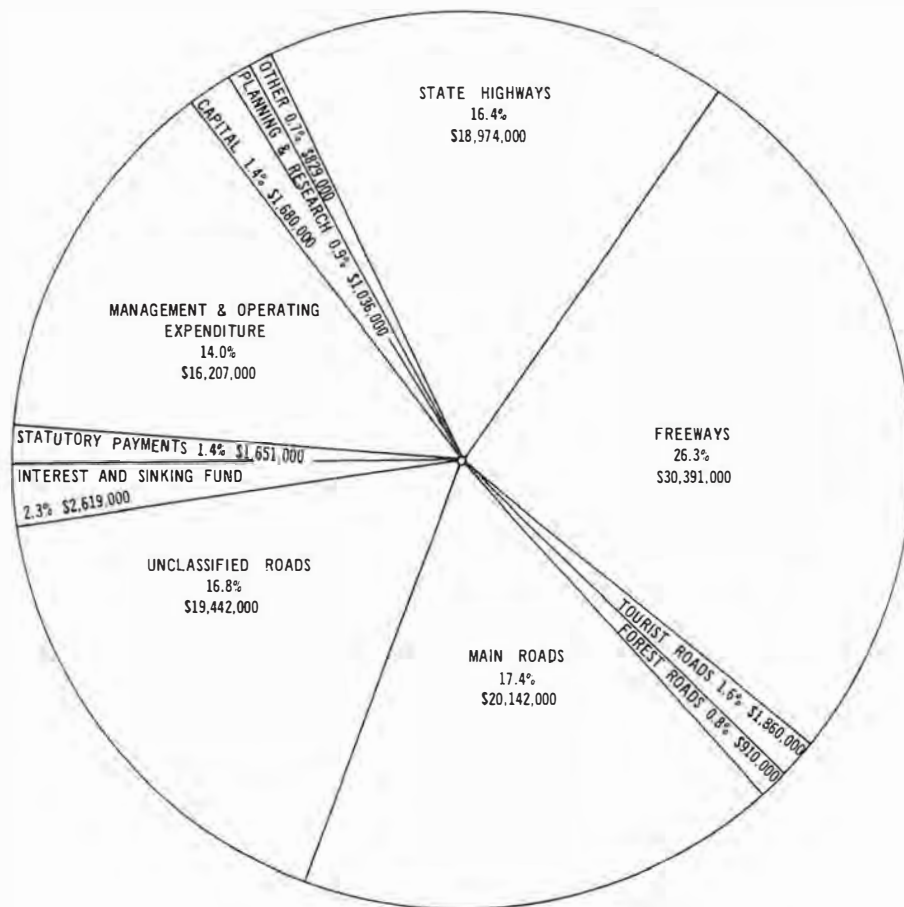

EXPENDITURE 1973-74

## EXPENDITURE

Expenditure in the form of cash payments during the financial year amounted to \$115,741,549 leaving a cash balance of \$831,610 to be carried forward into the financial year 1974/75. The Board's share of the grants to the State under the Commonwealth Aid Roads Act was fully expended.

The following table compares expenditure made, including that from the Roads (Special Projects) Fund, in the year 1973/74 with 1972/73.

Item	1972/73	1973/74
	\$	\$
Construction and maintenance of roads and bridges	83,611,424	92,548,559
Capital expenditure (plant, workshops, offices, etc.)	2,406,574	1,680,563
Planning and Research	1,157,324	1,035,694
Salaries, operating accounts and other administrative expenditure	12,123,433	16,206,533
Statutory payments to Traffic Authority Fund, Tourist Fund and Transport Regulation Fund	1,577,041	1,651,517
Interest and Sinking Fund payments	2,611,805	2,618,683
Totals:	<u>\$103,487,601</u>	<u>\$115,741,549</u>

## SHARING THE COSTS OF ROADWORKS

The Country Roads Act provides that no more than one-half of the amount expended from loan funds and one-third of the amount expended from the Country Roads Board Fund on main roads during the preceding financial year shall be apportioned between the various municipalities benefited thereby. The Act also provides that the amount apportioned to a council in respect of expenditure charged to the Country Roads Board Fund may be reduced where the cost of maintenance is excessive due to motor traffic not of local origin or to timber traffic. The revenue, valuation, and rating of the municipality and its financial obligations for loan expenditure on permanent works are taken into account in deciding the level of contribution by a council.

In September 1973 expenditure on main roads in financial year 1972/73 was apportioned in accordance with the Country Roads Act, resulting in the following distribution of expenditure other than Loan Fund expenditure:

Expenditure from Country Roads Board Fund	\$12,047,867
Expenditure from Commonwealth Aid Roads moneys	5,468,899
Expenditure from proceeds of ton/mile tax (Commercial Goods Vehicles Act)	3,137,217
Total:	<u>\$20,653,983</u>
Amount of Country Roads Board Fund Expenditure apportioned to councils	\$2,013,440

Within the limits of funds available, the Board made allocations to municipal councils for works on unclassified roads. The expenditure incurred from the allocations made by the Board in financial year 1973/74 compared with 1972/73 was as follows:

UNCLASSIFIED ROADS	1972/73		1973/74	
	C.R.B.	Council Contribution	C.R.B.	Council Contribution
	\$	\$	\$	\$
Construction and reconstruction	15,732,673	4,205,600	17,190,492	4,238,431
Patrol Maintenance	1,977,223	880,039	2,112,282	929,251
Total:	<u>\$17,709,896</u>	<u>\$5,085,639</u>	<u>\$19,302,774</u>	<u>\$5,167,682</u>

Municipal councils were not required to contribute towards the cost of works involving an expenditure during the year of \$44,630,517 on State highways, freeways, tourists' roads and forest roads.



## THE DECLARED ROAD SYSTEM

The total length of roads declared or proclaimed in Victoria under the Country Roads Act was 14,734 miles as at 30th June, 1974.

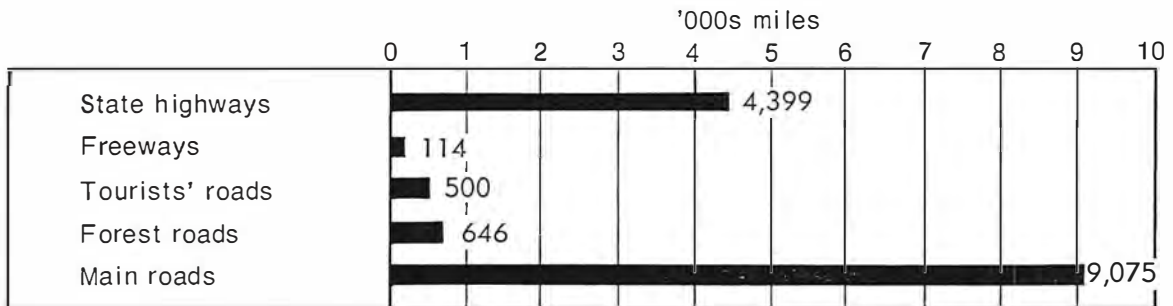

Apart from alterations consequent upon the declaration of newly completed sections of freeway, and the deviation from and widenings of existing declared or proclaimed roads the Board's declared and proclaimed road network was not altered during the year. The Board was not in a position to accept the additional financial responsibility which would be involved in the declaration of additional roads.

### STATE HIGHWAYS

State highways are the principal arteries forming interstate connections and links between the larger centres of population in the State. Some State highways in Victoria form part of the National Route system of highways with uniform route numbering throughout Australia.



*Reconstructed section of the Sunraysia Highway near Lamplough.*

The Board bears the full cost of both construction and maintenance works required to meet the needs of through traffic.

The total length of State highways was reduced by approximately 15 miles during the year, due mainly to the declaration of part of the former Princes Highway near Lara as a freeway.



The total expenditure of \$18,974,000 on Victoria's 32 State highways during the year included an amount of \$302,000 made available from the Roads (Special Projects) Fund. Appendix 1 includes a list of State highways declared by the Board, and details of the more significant works completed during the year on State highways are given in Appendix 2.



*The Princes Highway West at West Footscray.*

## **FREEWAYS**

A freeway is a road having dual carriageways with no direct access from adjoining properties and side roads. All crossings of a freeway are by means of overpass or underpass bridges, and traffic enters or leaves the freeway by means of carefully designed ramps.

The Board bears the total cost of all work on freeways. The total expenditure of \$30,391,000 on freeways during the year included an amount of \$7,202,000 made available from the Roads (Special Projects) Fund.



*The Mulgrave Freeway south-east from Wellington Road.*



The major freeway project completed during the year was the section of the Mulgrave Freeway from Springvale Road to Stud Road described on page 20 of this report. The Board also declared approximately 15 miles of the former Princes Highway West near Lara as the Princes Freeway (Lara Section).

During April 1974 the Board reviewed the names of the future freeways in the corridors of the Princes Highway East and the South Gippsland Highway and decided that:

- (a) the Eumemmerring Freeway will be known in future as the South Gippsland Freeway;
- (b) the Latrobe Valley Freeway will be known in future as the Princes Freeway.

The table in Appendix 1 lists the freeways constructed by the Board and opened to traffic. The significant works completed during the year are shown in Appendix 2.

## **TOURISTS' ROADS**

Tourists' roads proclaimed under the provisions of the Country Roads Act provide access to places of special interest to tourists, both in summer and winter. The Board bears the full cost of works required to cater for the needs of through traffic. In general the works are carried out under the direct supervision of the Board's staff.

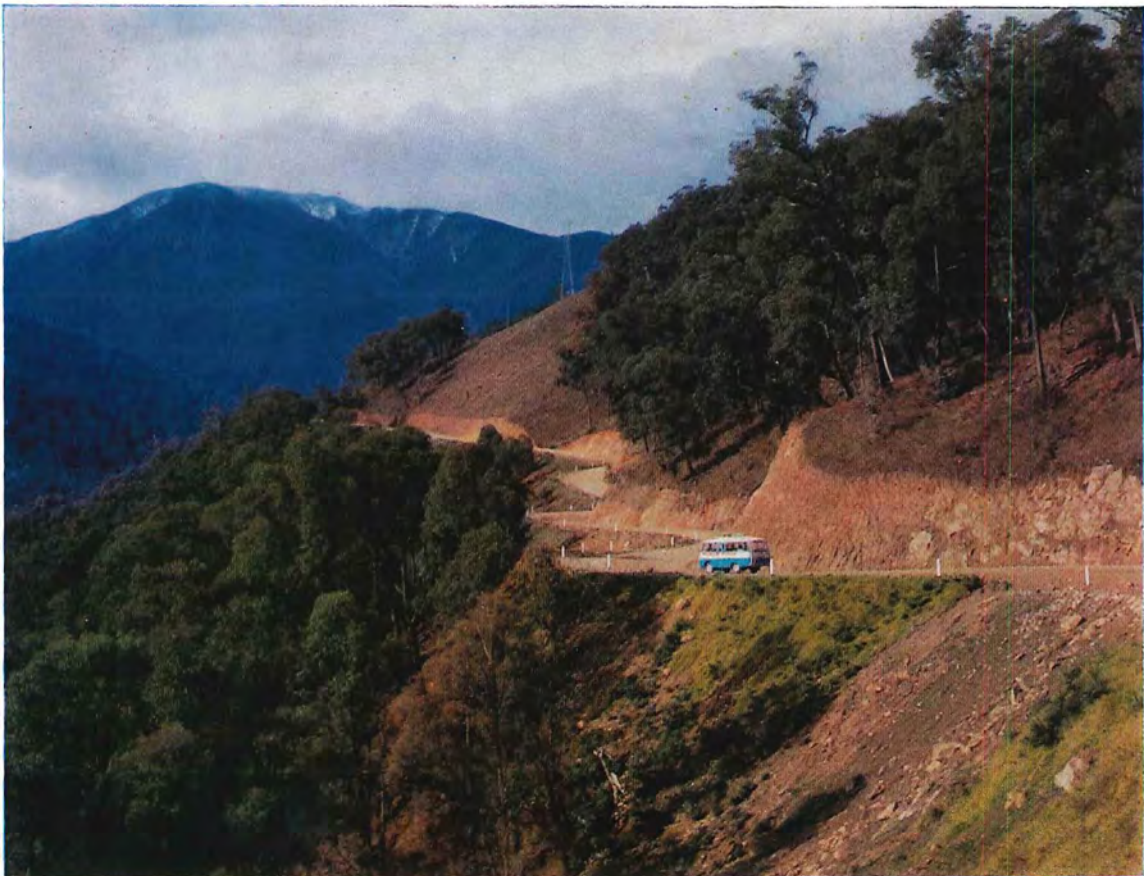

*The Bogong High Plains Road north of Mt. Beauty.*

Details of the more significant works carried out on tourists' roads during the year are listed in Appendix 3.

The table in Appendix 1 lists the tourists' roads proclaimed under the provisions of the Country Roads Act.

## **FOREST ROADS**

Forest roads proclaimed under the provisions of the Country Roads Act are situated within or adjacent to any State forest or in areas which are considered to be timbered, mountainous or undeveloped. The Board bears the full cost of works required to cater for the needs of through traffic, with approximately half the work carried out on these roads being undertaken by municipal councils on behalf of the Board.

Appendix 3 lists the more important works completed during the year.

The table in Appendix 1 lists the forest roads proclaimed under the provisions of the Country Roads Act.



## MAIN ROADS

Main roads are roads linking centres of population with other centres or with areas of industry, commerce, or settlement. Generally main roads are constructed and maintained by municipal councils to the satisfaction of, and with financial assistance from, the Board. In some cases at the request of the Council works are carried out under the direct supervision of the Board's staff.

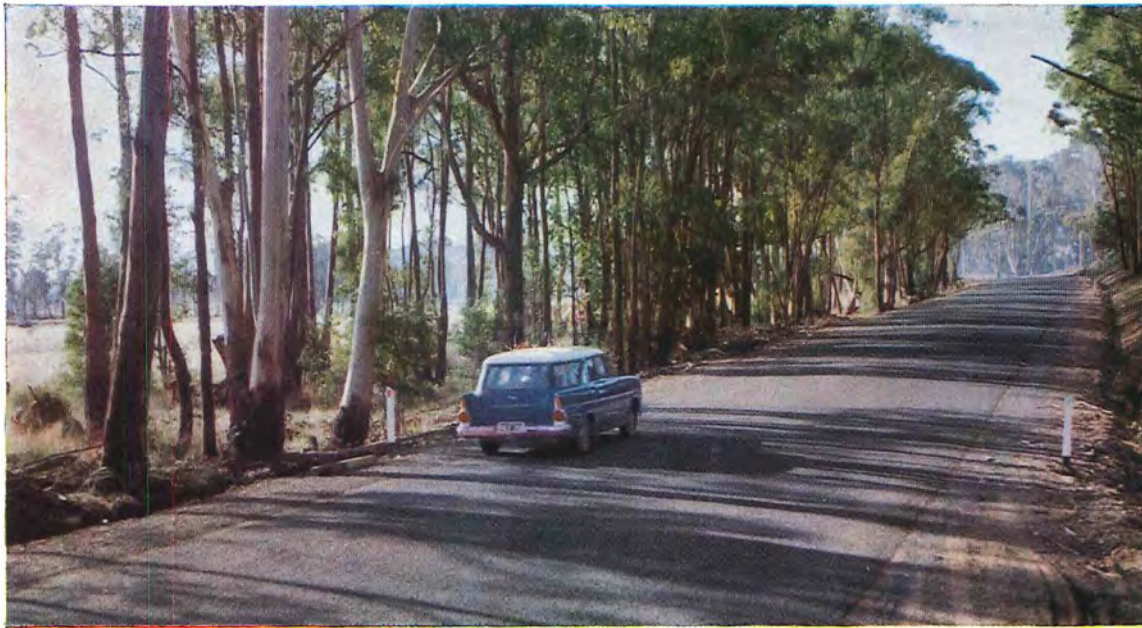

*Ballan Road south of Daylesford*

A summary of the more important works on main roads completed during the year is given in Appendix 4.

## UNCLASSIFIED ROADS

Roads which are not included in the Board's declared and proclaimed road system are referred to as unclassified roads. These roads are the responsibility of municipal councils, but each year the Board provides financial assistance towards the cost of construction and maintenance works, generally in accordance with priorities allotted by municipal councils.



*Hutchinsons Road in the Shire of Mansfield.*

Municipal contributions are determined at the time the allocation is made, and are based on many factors including the nature, extent, and location of the particular work and the financial position of the municipality concerned.

A list of the more significant works on unclassified roads carried out during the year with financial assistance from the Board appears in Appendix 5.

## ROAD CONSTRUCTION AND MAINTENANCE

Appendices 2 to 5 list the more significant works completed during the year with funds provided wholly or partly by the Board.

In Appendix 11, the Chief Engineer's Report, a more detailed and technical account of road construction and maintenance activities for the year is given.

The following table shows the miles of roads declared or proclaimed under the Country Roads Act as at 30th June, 1974, and the expenditure incurred on such roads during the year.

Road	Declared or Proclaimed Miles	Road Expenditure (including Special Projects)		
		Patrol Maintenance	Other Maintenance	Construction and Reconstruction
		\$	\$	\$
Freeways	114	626,000	88,000	29,677,000
State Highways	4,399	5,274,000	1,734,000	11,966,000
Tourists' Roads	500	713,000	115,000	1,032,000
Forest Roads	646	489,000	69,000	352,000
Main Roads	9,075	1,583,000	5,028,000	13,532,000
<b>TOTALS</b>	<b>14,734</b>	<b>8,685,000</b>	<b>7,034,000</b>	<b>56,559,000</b>

### MULGRAVE FREEWAY

During the year the section of the Mulgrave Freeway between Springvale Road and Stud Road was opened to traffic. This section together with the section between Stud Road and the Princes Highway provides a continuous length of 8.6 miles of freeway between the Princes Highway at Doveton and Springvale Road as an alternative route to the Princes Highway through Dandenong.

The conception of the Mulgrave Freeway occurred in the late 1950's when the Board investigated the requirements for road access in and around the developing industrial and residential areas of Dandenong. In consequence, a freeway system was designed around Dandenong in the early 1960's. A planned extension of this freeway system followed as a result of later investigations and became part of the freeway network recommended by the Metropolitan Transportation Committee in 1969.



*The Mulgrave Freeway at the Wellington Road interchange.*



In programming the construction of freeways to the south-east of Melbourne it was considered that funds should first be applied to the construction of the 3.5 miles of the Mulgrave Freeway between the Princes Highway at Doveton and Stud Road, Dandenong North, to relieve the Dandenong commercial and industrial centre of much through traffic. This length was completed and opened to traffic in November 1972.

Construction of the adjoining 4.7 mile section westerly from Stud Road to Springvale Road commenced in March 1971. The portion between Jacksons Road and Springvale Road was opened temporarily in September 1973, to assist traffic conditions during the football finals at V.F.L. Park, and then opened on a permanent basis in December 1973.

On 10th April 1974, the section of freeway between Jacksons Road and Stud Road was opened to traffic.

Traffic counts taken since 10th April 1974, indicate that the most heavily used section of the freeway is between Springvale Road and Jacksons Road where there is an average of 14,400 vehicles per 24 hour day.

Calculations which take into account reduced travelling times, vehicle operating costs, and accident costs, show an expected annual saving to the community of \$1.27 million for the construction of 8.6 miles of freeway at a cost of \$16.0 million.

Approximately 15,000 native trees and shrubs have been successfully established on the freeway reserve east of Stud Road. Similar treatment will be given to the newly opened section by planting in excess of 20,000 trees and shrubs.

## SPECIAL PROJECTS

The Roads (Special Projects) Fund was established by the Government in 1965 from increased motor registration fees imposed as from 1st July 1965.

Works to be financed from the Roads (Special Projects) Fund must be approved by the Governor in Council on the recommendation of the Treasurer of Victoria. Until 30th June 1974 two-thirds of the moneys credited to this fund were allocated by the Government for expenditure by the Melbourne and Metropolitan Board of Works in the Melbourne Metropolitan Planning Area and the remainder for expenditure by the Country Roads Board outside this area.

Expenditure from the Roads (Special Projects) Fund by the Board on behalf of the State Government during the year was \$7,643,000. Since the inception of the Special Projects scheme in 1965/66 the cost of work performed by the Board on Special Projects and charged to the Roads (Special Projects) Fund totals \$42,005,000.

Details of Special Projects on which work was carried out during the year are given in Appendix 6.

## LAND PURCHASE

During the year the Board paid compensation and costs totalling \$11,706,000 for land acquired or purchased for road purposes from owners of land.

The following table shows the number of land purchase transactions completed and the amount of compensation paid over the last five years:

	1969/70	1970/71	1971/72	1972/73	1973/74
Number of land purchase cases settled	1,117	1,022	977	865	864
Compensation and associated costs paid by the Board	\$5.29 M	\$5.00 M	\$5.14 M	\$10.07 M	\$11.71 M
Reimbursement to Councils for purchase of land for unclassified road works	\$0.18 M	\$0.26 M	\$0.33 M	\$0.46 M	\$0.88 M

New road proposals of a major nature require years of investigation and planning before road construction work can commence. During the pre-construction time the Board is often unable to define accurately the ultimate land requirements, or prefers not to expend public funds in the purchase of properties which will not be needed for many years. However, consideration is given to individual property owners who could be at a disadvantage because of proposed roadworks and if hardship is being suffered the Board may negotiate with the owner for the purchase of the property.

Properties purchased by negotiation are rented or leased through local estate agents until such time as they are required for roadworks and sold for removal. During the year houses owned by the Board and located on land required for imminent road construction were sold by auction for a total amount of \$22,516.

In some cases owners prefer the Board to purchase the whole of their properties where the portion required for road purposes has a significant effect on the continuing usage of the remainder of the property. The portion not required for road purposes can later be sold by the Board. During the year the Board sold such areas of vacant land for \$189,941 and nine residential properties with dwellings for a total of \$168,750.

The Land Compensation Act 1973 which came into force on 1st June 1973, brought with it increased benefits to landowners whose property is required for road purposes. The new legislation included provisions for a 90% advance of the estimated compensation, interest free loans, the payment of solatium and the making of estimates within six months. It also introduced new principles involving the right of an owner to claim negotiating costs and for special features.

The extra benefits available to land owners have resulted in an increase in the volume and complexity of the work of the Board's Estates Section as landowners or their solicitors exercise their rights under the new provisions.

## CONTRACTS

### Contracts under the Board's Direct Supervision

Details of the types and numbers of contracts entered into and their respective values, together with a comparison with those of financial year 1972/73, are shown in the following table:

Type of Contract	1973/74		1972/73	
	No. of Contracts	Value	No. of Contracts	Value
		\$		\$
Road Construction —				
Over \$1,000,000	1	7,255,946.63	2	7,809,298.24
\$100,000 to \$1,000,000	6	1,867,422.36	—	—
Under \$100,000	1	54,762.20	6	371,244.95
Supply of Roadmaking Materials	114	3,320,139.31	55	2,225,105.20
Bituminous Treatment and Supply of Materials	49	4,208,729.58	111	5,203,723.40
Bridge Construction	32	3,184,643.28	22	2,231,912.35
Manufacture of Bridge Components and Fabricated Steel	17	736,611.80	9	560,570.12
Supply of Reinforced Concrete Pipes and Box Culverts	15	907,638.00	20	1,152,970.25
Supply of Road and Bridge Construction Equipment	35	795,999.98	32	1,353,929.04
Divisional Facilities	1	32,000.00	—	—
Stores	15	2,003,256.00	10	977,372.40
Miscellaneous Services	18	640,400.97	17	270,700.60
<b>Totals</b>	<b>304</b>	<b>\$25,007,550.11</b>	<b>284</b>	<b>\$22,156,826.55</b>

These totals include contracts being financed from the Roads (Special Projects) Fund, which for the year amounted to 23 in number for a total value of \$2,635,177.80.

### Contracts under Councils' Supervision

During the year the Board approved the acceptance by municipal councils of 197 tenders for a total amount of \$5,329,396.00 for road and bridge works for which the Board allocated funds in whole or part. In 1972/73, 234 tenders were approved for a total amount of \$5,742,823.00.

The Board also approved the use of 88 municipal contracts for the supply of materials for works partly financed from funds provided by the Board compared with 83 last year.

As a result of inflation, many of the Board's contractors found difficulty in completing fixed price contracts. The Board therefore decided to include a price variation clause in construction contracts having an estimated duration of more than eighteen months. The approved clause was based on 80% of the variation in the Consumer Price Index during the currency of the contract.

The Board also permitted price variation clauses based on the determinations of the Prices Justification Tribunal, in contracts for the supply of tyres, petrol and bituminous products.

## BITUMINOUS SURFACING

The application of bituminous surfacing to a road confers many benefits, namely:—

- (i) a protection against rainwater penetration;
- (ii) a reduction in the evaporation of moisture in the layers of material below the surface;
- (iii) a reduction in the rate of pavement surface wear;
- (iv) a reduction in the tractive effort required by a vehicle travelling on the road;
- (v) a reduction in the cost of road maintenance;
- (vi) the maintenance of the good riding qualities of the pavement;
- (vii) the provision of a dust free, skid resistant, non-glare surface over a long period.

A bituminous surface may be provided by the spraying of a bituminous binder covered immediately with a layer of uniformly spread aggregate which is compacted by rolling. Alternatively the bituminous surface may be applied by the spreading of a pre-mixed layer of bitumen and aggregate produced at fixed mixing plants.

The total length of bituminous surfacing including both sprayed work and plant mix work completed during the year amounted to 2,942 miles at an approximate cost of \$12,073,000.

The Board's 17 mobile bituminous surfacing units together with plant owned by municipal councils and contractors completed 2,860 miles of sprayed work at a cost of approximately \$8,420,000.

Contractors operating from fixed asphalt plants completed 82 miles of plant mix work on densely trafficked roads at a cost of approximately \$3,403,000 using 230,420 tons of bituminous concrete.



*Spreading aggregate on a sprayed bitumen binder.*

The lengths of the various types of work completed during the year were:

- 158 miles of sealing widened pavements,
- 13 miles of initial sealing on dual carriageways,
- 402 miles of restoration of sealed coats on reconstructed sections,
- 332 miles of final sealing on initial treatments,
- 1,455 miles of maintenance retreatments,
- 97 miles sealed on behalf of other State and municipal authorities,
- 485 miles of extensions to the bituminous sealed road system of the State including 68 miles of roads declared or proclaimed under the Country Roads Act.



The following quantities of materials were used by the Board or by contractors during the year on bituminous surfacing works:

MATERIAL	QUANTITY
Bitumen for sprayed work	26,800 tons
Bitumen for bituminous concrete	12,300 tons
Aggregate for sprayed work	332,364 cubic yards
Aggregate for bituminous concrete	194,000 cubic yards
Other bituminous materials for sprayed work and maintenance	13,350 tons

The total length of sealed roads in the Board's declared or proclaimed road network is 13,431 miles or 91 per cent of the total length of declared or proclaimed roads.

## LINEMARKING

Linemarking operations were carried out during the year by ten linemarking units, viz. three large machines, five medium sized units and two small machines.

During the year the Board's units maintained linemarking and roadmarking on 8,621 miles of road. This length is an increase of 4% over the previous year. The comparison with last year is shown in the following table:

ROAD	1972/73	1973/74
	Miles	Miles
State highways and freeways	4,216	4,218
Other declared or proclaimed roads under the Country Roads Act	3,231	3,495
Unclassified roads	846	908
<b>Totals</b>	<b>8,293</b>	<b>8,621</b>

The total length of linemarking expressed as miles of equivalent standard stripe (i.e. with the solid line expanded to the equivalent of the standard 10 feet line with 30 feet gap) was 26,235 miles.

The total expenditure incurred on linemarking during the year was \$652,327. The total costs and the quantities of materials used in 1972/73 and 1973/74 are shown below:

	1972/73	1973/74
Total expenditure	\$618,655	\$652,327
Roadmarking paint used	71,000 gals.	59,792 gals.
Reflective glass beads used	247 tons	212 tons
Raised pavement markers used	3,589	7,785

## ROADS TO SNOW RESORTS

During the summer months the following major improvements were carried out on those tourists' roads which give access to the winter snow fields:

### The Alpine Road

Widening 3.0 miles between Harrietville and The Meg in preparation for sealing next summer.

Construction of the approaches to Livingstone Creek bridge and the junction with Swifts Creek-Omeo Road.

### Mount Buffalo Road

Widening and sealing the final 0.5 mile between the Cathedral and the Cresta Valley.

## **Bogong High Plains Road**

Widening 4.0 miles between the Gate House and Crankie Charley of which 2.1 miles was sealed.



*Clearing snow on the Mt. Buffalo Road.*

## **STREET LIGHTING**

An amendment to the Country Roads Act in 1971 provided for the Board, the electricity supply authority, and the municipal council concerned to share the costs of street lighting on State highways in cases where the lighting is not of a standard lower than the minimum standard determined by the Street Lighting Committee. This statutory committee set up under the Country Roads Act consists of one representative from the State Electricity Commission of Victoria, the Municipal Association and the Country Roads Board.

During the year, eleven existing street lighting installations and five new installations on State highways were approved by the Street Lighting Committee for cost sharing purposes.

The total annual tariff for the existing 42.3 miles of lighting and the additional 7.1 miles of new lighting approved by the Committee to date amounts to approximately \$169,200 which, under the Country Roads Act, is shared equally between the Board, the Commission and the municipal councils concerned.

The Country Roads Act was amended during the year to extend the cost sharing provisions for street lighting to main roads declared under the Country Roads Act. Procedures were evolved for the evaluation of main road lighting to enable the Street Lighting Committee to consider and, where appropriate, approve installations for cost sharing.

## **BRIDGES**

### **CONSTRUCTION OF NEW BRIDGES**

Work commenced during the year on the construction of 143 new bridges estimated to cost \$14.75 million either under the direct supervision of the Board's staff or under municipal supervision with financial contribution from the Board. The following table



shows the number and estimated cost of bridge projects commenced in financial years 1972/73 and 1973/74:

Description	1972/73		1973/74	
	No.	Estimated Cost	No.	Estimated Cost
Bridges commenced under the supervision of the Board's staff	58	\$10,100,000	58	\$12,400,000
Bridges commenced under municipal supervision with financial assistance from the Board	73	\$1,250,000	85	\$2,350,000
<b>Total Bridges Commenced</b>	<b>131</b>	<b>\$11,350,000</b>	<b>143</b>	<b>\$14,750,000</b>

### LARGE BRIDGES COMPLETED IN RURAL AREAS

Some of the larger bridges completed in rural areas during the year under the direct supervision of the Board's staff are:

- (a) **Dartmouth Road (previously Callaghans Road) — Mitta Mitta River, Shire of Tallangatta:** A six-span composite steel beam and reinforced concrete bridge 270 feet long and 28 feet between kerbs.



*Bridge over the Mitta Mitta River, Dartmouth Road, Shire of Tallangatta.*

- (b) **Murray Valley Highway—Ovens River Flats, Parola's Bridge, Shire of Yarrawonga:** A four-span reinforced concrete bridge 140 feet long and 28 feet between kerbs.
- (c) **Kiewa Valley Highway — West Kiewa River at Mt. Beauty, Shire of Bright:** A three-span reinforced concrete bridge 106 feet long and 28 feet between kerbs.
- (d) **Western Freeway (Pentland Hills Section) — Overpass at 38 mile post, Shire of Bacchus Marsh:** Twin prestressed concrete beam and reinforced concrete bridges, one 312 feet long and the other 280 feet long, each 36 feet between kerbs.



- (e) **Mornington Peninsula Freeway — Burrell Road Overpass, Shire of Flinders:** A three-span prestressed and reinforced concrete flat slab bridge 259 feet long by 28 feet between kerbs, plus two footways each 6 feet wide.



*The Burrell Road bridge, Mornington Peninsula Freeway.*

- (f) **Hume Freeway (Wallan-Broadford Section) — Wallan-Whittlesea Road Overpass, Shire of Kilmore:** A two-span post-tensioned and reinforced concrete box girder bridge, 272 feet long by 28 feet between kerbs.

Some of the larger bridges completed during the year under municipal supervision with financial assistance from the Board are:

- (a) **Livingstone Creek — Day Avenue, Shire of Omeo:** A three-span composite steel girder and reinforced concrete bridge 150 feet long and 28 feet between kerbs.



*Bridge over Livingstone Creek, Day Avenue, Shire of Omeo.*



- (b) **Glenelg River and Sugarloaf Creek — Coleraine-Nareen-Mooree Road, Shire of Wannon:** Two reinforced concrete U-slab bridges, one being 175 feet long and the other 70 feet long, each 28 feet between kerbs.
- (c) **Wades Creek — Traralgon West Road, Shire of Traralgon:** A corrugated galvanized steel pipe culvert of five cells each 12 feet in diameter and 120 feet long under a 15 feet depth of fill.
- (d) **Jack River — Jack River Valley Road, Shire of Alberton:** A two-span prestressed concrete beam and reinforced concrete bridge, 100 feet long and 24 feet between kerbs.



*Jack River Valley Road, Shire of Alberton.*

- (e) **Stony Creek — Yarram-Morwell Road, Shire of Alberton:** A five-span reinforced concrete U-slab bridge 150 feet long and 28 feet between kerbs.
- (f) **Sandy Creek — Gower-Goonooer Road, Shire of Korong:** A four-span reinforced concrete U-slab bridge, 120 feet long and 28 feet between kerbs.

## **METROPOLITAN BRIDGES AND OVERPASSES**

Amongst the larger vehicular bridges in the metropolitan area completed under the direct supervision of the Board's staff, were:

- (a) **Calder Freeway — Albion-Broadmeadows Rail Overpass, City of Keilor:** Twin three-span composite steel girder and reinforced concrete bridges each 147 feet long, one being 50 feet between kerbs and the other 38 feet between kerbs.
- (b) **Calder Freeway — Woorite Place Overpass, City of Keilor:** A two-span prestressed concrete inverted tee beam and reinforced concrete overpass 200 feet long and 48 feet between kerbs plus two footways each 6 feet wide.
- (c) **South Gippsland Freeway—Overpass at the Eastern Railway, Shire of Cranbourne:** Twin composite steel girder and reinforced concrete overpass structures, each 136 feet long and 34 feet between crash barriers.



- (d) **Frankston Freeway—Overpass on Seaford Road, City of Frankston:** A two-span prestressed concrete beam and reinforced concrete bridge, 202 feet long and 66 feet between outer road kerbs plus two footways each 6 feet wide.



*Seaford Road overpass of the Frankston Freeway during construction.*

## **GRADE-SEPARATED PEDESTRIAN CROSSINGS**

### **Restoration of Pedestrian Access across Freeways**

One pedestrian overpass across a freeway was completed during the year. This crossing at Seaford Road in the City of Frankston is across the Frankston Freeway. The structure is a two-span prestressed concrete beam and reinforced concrete overpass 299 feet long and 6 feet wide.

### **The State Government's Scheme for Grade-separated Crossings to Serve Schools**

Under this scheme introduced by the State Government in 1965, applications for subsidies towards the replacement of at-grade school crossings on busy roads are submitted by municipal councils to the Board.

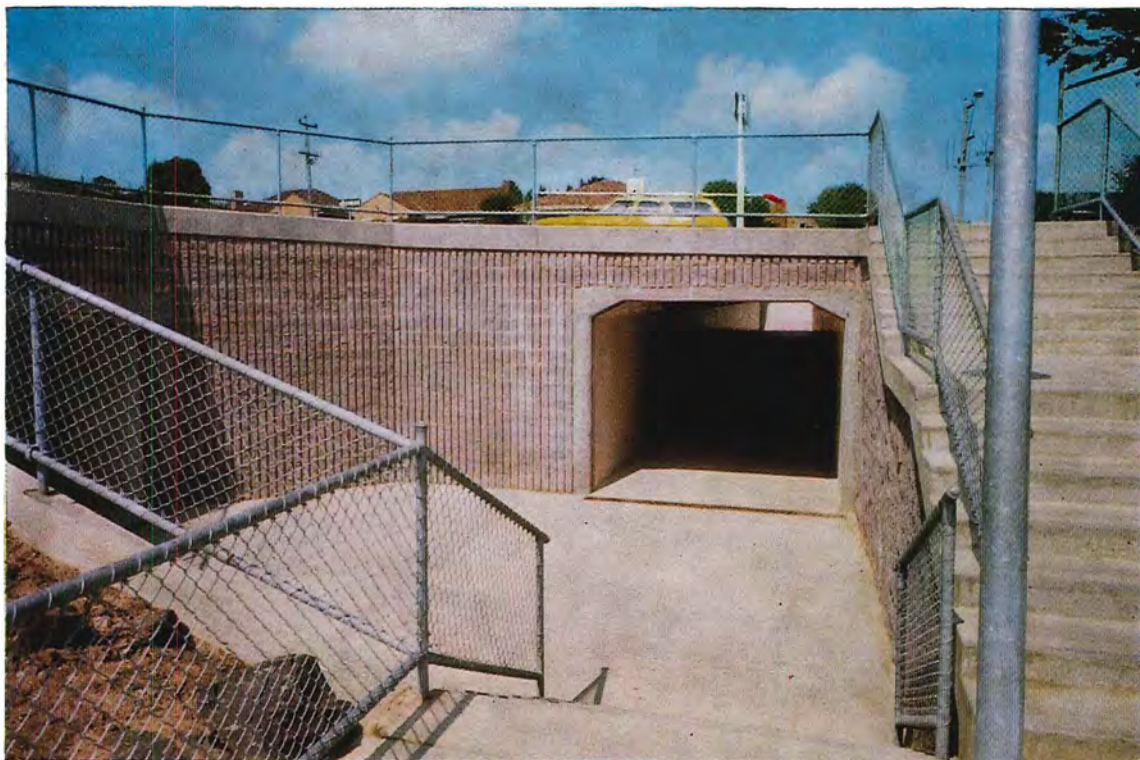

*Pedestrian underpass of the Burwood Highway at Bennettswood.*

Priorities are then allotted by the Road Safety and Traffic Authority in conjunction with the Board taking into account traffic volume, average speed of traffic, the number and age range of children crossing the road, and the type of road.

Costs of approved projects are shared equally between the Government, the Board, and the municipal council concerned.

Two further crossings in this category were completed during the year:

- (i) **Burwood Highway — Bennettswood Pedestrian Underpass, City of Box Hill:** A reinforced concrete pedestrian subway 132 feet long and 10 feet wide giving access to Bennettswood Primary School.
- (ii) **Manningham Road—Manningham Primary School and Templestowe High School, City of Doncaster and Templestowe:** A prestressed concrete beam and reinforced concrete pedestrian overpass 390 feet long and 6 feet wide.

### Assistance to Municipal Councils

Following a decision by the State Government and the Preston City Council to construct a pedestrian overpass over Bell Street at Gowerville Primary School, Belgrove Street, as a matter of urgency, the Board prepared the plans and specifications and completed the construction of the crossing within 5 months. The overpass is 130 feet long and 6 feet between kerbs. The Council contributed one-third of the cost and the State Government two-thirds.

### BRIDGE AND CULVERT MATERIALS

The following bridge and culvert materials purchased either directly by the Board or by municipal councils, were used during the year on works financed wholly or partly by the Board:

ITEM	AMOUNT
Reinforced concrete pipes	\$918,900
Reinforced concrete box culverts	\$388,000
Corrugated steel pipes and culverts	\$55,300
Corrugated steel guardrail (90,000')	\$111,200
Precast concrete bridge units (18,000 tonnes)	\$1,020,000
Fabricated reinforcing steel (4,800 tonnes)	\$946,500
Welded steel girders, etc.	842 tonnes

## ELIMINATION OF RAILWAY LEVEL CROSSINGS

Since the inception of the State Government Scheme in 1954, the Board and the Victorian Railways have replaced 60 railway level crossings with overpasses and underpasses as a means of reducing accidents and traffic delays. The work represents a total expenditure of approximately \$30.6 million.

Since 1970/71 expenditure on such projects has been shared on the basis of the Country Roads Board 50%, Victorian Railways 5%, and the Level Crossings Fund 45%.

The purposes for which the Level Crossings Fund may be used are:—

- (a) the elimination of level crossings or the provision of alternative routes to enable road traffic to avoid level crossings;
- (b) the provision of lights, signs and lighting at level crossings, and improved approaches to level crossings;
- (c) any other works calculated to improve the flow of traffic across, or to reduce the danger at, level crossings.



The following grade-separated overpass was completed during the year:

**Millers Road — Paisley**

A road-over-rail overpass of the Geelong railway. Approximately 11,000 vehicles used the level crossing between 7.00 a.m. and 7.00 p.m. daily and approximately 60 trains use the railway in a whole day. The Board was the constructing authority. The total cost of the project was \$1,100,000.



*Road over rail overpass on Millers Road, Paisley.*

The following projects were commenced during the year:

**Princes Highway West — Colac**

A road-over-rail overpass of the Port Fairy railway which will make it possible to close three level crossings. Approximately 5,000 vehicles use the level crossings in a whole day and the normal rail traffic is 14 trains in a 24 hour day. The Board is the constructing authority. The estimated cost of the project is \$870,000.

**Melbourne Road — Spotswood**

Construction of a road-over-rail overpass of the Newport-Sunshine railway. Approximately 11,000 vehicles use the level crossing between 7.00 a.m. and 7.00 p.m. daily, and approximately 40 trains use the railway in a 24 hour day. The Board is the constructing authority. The estimated cost of the project is \$1,900,000.

## TRANSPORTATION STUDIES

Studies to determine the present and future requirements for transportation facilities in the urban areas of Geelong, Ballarat and Bendigo commenced in 1969/70. The studies were carried out by consultants supervised by a committee acting on behalf of the Board. Seven-eighths of the cost of the studies was met by the Board with local bodies in each study area bearing the remaining one-eighth.

### GEELONG

The transportation study was completed during the 1972/73 year, resulting in recommendations by the consultants of three alternative road improvement proposals. The first alternative involved only those new arterial roads which were already envisaged in the Geelong Town Plan. The second alternative was based on a north-south freeway by-passing the urban centres to the west, and the third was for a central

freeway which would attract the maximum possible proportion of the local traffic demand. A further study of environmental and social benefits and costs of these alternatives is currently being undertaken by a consortium of consultants engaged by the Geelong Regional Planning Authority with financial assistance from the Board.

## BALLARAT

The consultant's final report and recommendations were released in December 1971. The recommendations generally provide for improvements south of Sturt Street, the development of a by-pass through the northern suburbs, and a freeway by-pass further north to cater for through traffic not destined for Ballarat. Representatives of the Board and municipal councils have conferred to resolve matters arising from the transportation study. The Board has accepted responsibility for the planning and design of the outer area freeway by-pass and for redevelopment of the Midland Highway approach to Ballarat from the south.

Other recommendations for major central area road improvements have not yet been accepted for implementation, but a traffic management study began in central Ballarat during the year with the aim of developing short term road improvements.

## BENDIGO

The Bendigo Transportation Study was carried out by consultants acting for a Study Committee representing the Board, the City of Bendigo, the Borough of Eaglehawk, the Shire of Strathfieldsaye, the Shire of Marong, the Shire of Huntly, the Transport Regulation Board, and the Ministry of Transport. The Study was concluded during 1972.

The five municipal councils concerned and the Board have adopted the consultant's recommended road plan in principle for broad planning purposes. The main features of the recommended plan are a circumferential route around the city centre, a direct route from the Calder Highway at Golden Square to Wills and Myers Streets, and a direct route from Strathfieldsaye Road to Myrtle Street. The Board has accepted responsibility for the preliminary survey and design work for some major arterial roads around the central business area.

On behalf of the Bendigo Transportation Study Committee the Board prepared a non-technical account of the reasons for, the conduct, and the recommendations of the Study for the information of the people of Bendigo and its surrounding areas.

On Saturday 8th June 1974, this account was presented in the form of a four page supplement to the Bendigo Advertiser. Circulation of the supplement was estimated at almost 19,000 copies.

The summary of the supplement is repeated here as an example of the easily understood nature of the presentation:

"Time will wait for no one. It is the responsibility of the local municipal councils and the C.R.B. to look ahead to ensure that adequate roads, public transport and parking facilities are provided for in the future.

In a nutshell, some points to remember about the Bendigo Transportation Study and its recommendations are:

- the road improvements are required for traffic generated within Bendigo itself
- the existing road system in Bendigo is very old and will not cater for the traffic needs of the future
- the recommended road network will greatly improve the present road system
- the present character of the Bendigo urban area will not be changed by implementation of the scheme
- provision of a well designed, balanced road network will enhance the quality of life in Bendigo
- an improved road system will mean greater efficiency to the public transport system
- diversion of through traffic from the commercial centres and local residential streets will lower accident rates and save lives."

For people with a closer interest in the Study and its recommendations, an information centre was set up in the committee rooms of the Bendigo City Offices on Monday, 10th June, 1974. Photographs and plans showing the results of the Study were displayed and members of the Board's staff and staff of the City of Bendigo were available to present and explain all aspects of the information resulting from the Study.

## NATIONAL PARKS ROADS

The State Government again provided \$100,000 loan funds for expenditure on roads and associated purposes in or near National Parks. The loan funds are repayable by the Board.

Allocations were made by the Board after consultation with the National Parks Service for works in or near —

Bulga National Park in Alberton Shire  
Ferntree Gully National Park in Sherbrooke Shire  
Fraser National Park in Alexandra Shire  
Glenaladale National Park in Bairnsdale Shire  
Hattah Lakes National Park in Mildura Shire  
Kingleake National Park in Eltham and Whittlesea Shires  
Lind National Park in Orbost Shire  
Mount Buffalo National Park in Bright Shire  
Mount Eccles National Park in Minhamite Shire  
Mount Richmond National Park in Portland Shire  
Organ Pipes National Park in Keilor City and Bulla Shire  
Port Campbell National Park in Heytesbury Shire  
Tarra Valley National Park in Alberton Shire  
Wilson's Promontory National Park in South Gippsland Shire  
Wyperfeld National Park in Karkaroc Shire.

The works consisted of construction and sealing of access roads and roads within National Parks, parking areas, and the maintenance of roads and parking areas already constructed. The works were carried out either by the Board or the municipal council concerned.

The Government has made loan funds totalling \$1,097,000 available for these purposes since 1st July 1963.

## ROADS OF TOURIST INTEREST

The State Government again provided loan funds amounting to \$200,000 during the financial year for expenditure on roads of a tourist nature other than roads proclaimed as tourists' roads under the provisions of the Country Roads Act.

As in previous years allocations for particular projects were made by the Board after consultation with the Ministry of Tourism. The total loan funds made available since 1960 is \$2,794,000. The loan moneys are repayable by the Board.

The allocations made in financial year 1973/74 included amounts for work on the western access road to Mount Baw Baw in the Shire of Narracan, an access road to the Lal Lal Blast Furnaces in the Shire of Buninyong, Sundial Road in the Grampians area within the Shire of Stawell, and the Cape Paterson-Inverloch Road in the Shire of Woorayl.

Significant progress in the provision of adequate access to many tourist attractions in Victoria has been possible from the Government's allocations since 1960, even though the applications for financial assistance far exceed the amount of funds available.

The Board is required to make an annual payment into the Tourist Fund amounting to two per cent of the amount credited to the Country Roads Board Fund in the previous year from receipts under the Motor Car Act. An amount of \$708,555 was paid during the year. The Tourist Fund is administered by the Ministry of Tourism.

## MUNICIPALITIES FOREST ROADS IMPROVEMENT FUND

The Municipalities Forest Roads Improvement Fund was established in the State Treasury in 1955 for the purpose of assisting municipal councils in the improvement and protection of roads adjacent to State Forest areas to facilitate the extraction of forest produce.



The Board's Divisional Engineers and the appropriate Forests Commission Officers combine to determine the priorities of eligible works. Allocations for particular works are made by the Board with the agreement of the Forests Commission.

An amount of \$50,000 was authorized to be contributed to the Fund by the Government during the year. Authorized contributions to the Fund to 30th June 1974 total \$590,000.

Outstanding applications for assistance from the Fund at present total approximately \$300,000. The limited funds have enabled grants to be made for only the most urgent works.

## CONTROL OF HEAVY TRAFFIC

For safety reasons, and to protect bridges and the pavements of the road system, limits are imposed by law on the width, height, length, and weight of vehicles and the loads they carry on public roads. These limits are specified in the Motor Car Act, but at times it is necessary to permit the movement of vehicles and loads which exceed the statutory limits. The Board meets this responsibility by issuing permits for large vehicles to use specified routes of travel at times when inconvenience to other road users will be at a minimum, and where there is little risk of damage to roads and bridges.

The Board is charged with the responsibility of controlling the movement of over-dimensional or heavy vehicles on the Board's declared or proclaimed roads and for journeys which include unclassified roads in two or more greater metropolitan municipalities as defined under the Motor Car Act. Policing and enforcement is effected by a team of 24 specially trained Traffic Officers and Assistant Traffic Officers together with four members of the Victoria Police operating from Head Office and Divisional Offices.

The following table sets out the number and types of permits issued during the year compared with those issued during financial year 1972/73:

	1972/73	1973/74	Increase
Single trip permits issued	24,128	28,138	17%
Annual permits issued	3,935	4,262	8%
Total number of permits issued	28,063	32,400	15%

The heaviest loads for which permits were issued during the year were for two underground boring machines carried from Melbourne to Dandenong in two loads each weighing 146 tons. Permits issued for loads of 70 tons or more numbered 339 and these included 14 permits for loads of 100 tons or more.

The number of offences reported by the Board's staff and the Police Officers on attachment was 6,582. Over 91% of these offences were successfully prosecuted. Total fines and costs resulting from these cases was \$397,815 payable to Consolidated Revenue.

The offences included overloaded axles and axle groups, excess length, excess height, excess width, excess speed, failure to comply with permit conditions and refusing to allow vehicles to be weighed.

## LEGISLATION AFFECTING THE BOARD

Legislation enacted during the year which affected the Board included the following:

### **Country Roads (Amendment) Act 1973, No. 8489**

This Act, which was proclaimed to come into operation on 3rd June 1974, extended to main roads declared under the provisions of the Country Roads Act the existing provisions relating to street lighting on declared State highways.

### **Metropolitan Bridges Highways and Foreshores Act 1974, No. 8573**

Amongst other things this Act provided for:

- (a) the repeal of Division 2 of Part VI of the Melbourne and Metropolitan Board of Works Act 1958 relating to metropolitan main highways and metropolitan bridges;
- (b) the inclusion in the Country Roads Act of definitions of ancillary works, maintenance, permanent improvements and permanent works as generally defined in the Melbourne and Metropolitan Board of Works Act;

- (c) the transfer of highway and bridge assets and liabilities from the M.M.B.W. to the C.R.B.;
- (d) the substitution of the Country Roads Board for the Melbourne and Metropolitan Board of Works in certain contracts and agreements;
- (e) the provision of a certificate by the Chairman of the Melbourne and Metropolitan Board of Works as evidence that any asset, liability or instrument is a bridges and highways asset, liability or instrument;
- (f) legal proceedings by or against the Melbourne and Metropolitan Board of Works relating to roading responsibilities to be carried on by or against the Country Roads Board;
- (g) all funds vested in or held by the Melbourne and Metropolitan Board of Works for its highways and bridges functions to be transferred to and vested in the Country Roads Board;
- (h) no compensation to be paid to any person in respect to anything arising out of the Act;
- (i) the declaration of existing M.M.B.W. metropolitan main highways as freeways, State highways or main roads as appropriate under the provisions of the Country Roads Act;
- (j) the transfer of M.M.B.W. staff to the C.R.B. under certain conditions.

The Act received the Royal Assent on 14th May 1974, and on 25th June 1974 the Governor in Council proclaimed the 1st July 1974 as "the appointed day" for the purposes of the Act, i.e. the day on which the transfer of responsibilities and staff from the M.M.B.W. to the C.R.B. would take place.

#### **Ministry of Transport (Transport Fund) Act 1974, No. 8549**

This Act, amongst other things, created a Transport Fund into which is to be paid:

1. Out of the Consolidated Fund an amount equal to one-fifth of one per centum of the gross revenue of the Victorian Railways Board paid to the Treasurer in respect of the financial year then last past.
2. By the Melbourne and Metropolitan Tramways Board an amount equal to one-quarter of one per centum of the gross revenue of that Board in respect of the financial year then last past.
3. By the Transport Regulation Board an amount equal to ten per centum of the total fees (including fees relating to licences) paid into the Transport Regulation Fund in respect of the financial year then last past.
4. All moneys required to be paid into the Transport Fund pursuant to sub-section 5 of Section 8 of the Motor Car Act 1958. In the past revenue obtained under Section 8 of the Motor Car Act, i.e. additional registration fees paid on initial registrations and subsequent change of ownership, were paid one-third into the Level Crossing Fund and two-thirds into the Country Roads Board Fund.
5. Moneys from time to time appropriated by Parliament for the purposes of this Act.

The Act also provides that out of the Transport Fund there shall be paid all such moneys as the Minister directs, to be applied towards the cost of any project or undertaking or research project in relation to the improvement, development or better co-ordination of transport in Victoria. When giving the Second Reading speech in the Legislative Assembly on the 20th March 1974, the Minister of Transport stated, inter alia "Initially the Fund will be used to double the rate at which road-rail grade separation projects and pedestrian overpasses are proceeding, to improve level crossing protection at railway lines, to embark upon a programme of construction of passenger interchange facilities and to finance greater research for transport planning."

The Act also—

- (a) increased the additional registration fees required to be paid under Section 8 of the Motor Car Act 1958 by a flat amount of \$3 and after deducting the cost of collection provided for the remaining moneys to be paid into the Transport Fund;
- (b) repealed Section 115 of the Country Roads Act which dealt with the establishment of the Level Crossings Fund;
- (c) provided for all moneys standing to the credit of the Level Crossings Fund at 30th June 1974 to be transferred to the Transport Fund.

## **Local Government (Amendment) Act 1974, No. 8557**

Amongst other things this Act made provision for municipal councils to:

- (a) prepare proposals for the declaration of any street or road or any part of any street or road to be a shopping mall and to prohibit or restrict the entry of vehicles thereto either absolutely or during certain hours.  
(Councils shall not prepare a proposal in respect of a road or any part of a road declared or proclaimed under the Country Roads Act without first obtaining the consent in writing of the Country Roads Board.)
- (b) prepare proposals for the closure of any street or road or any part of any street or road to through traffic.

## **THIRTIETH CONFERENCE OF MUNICIPAL ENGINEERS**

The 30th Conference of Municipal Engineers was held in the Board's theatrette on the 19th and 21st March 1974, concluding with a tour of the Melbourne Underground Rail Loop on 22nd March.

The Conference was conducted under the chairmanship of Mr. R. E. V. Donaldson and officially opened by the Hon. E. R. Meagher, M.B.E., E.D., M.P., Minister of Transport. Approximately 250 engineers including representatives of most Victorian municipalities, and many State Government Departments and Instrumentalities attended the conference. Again the Board was pleased to welcome some local government engineers from Tasmania.

In recent years a feature of the Conference has been reports by engineers on overseas study tours made during the preceding year. This year there were five such reports on different themes — Development of New Towns, Planning and the Environment, Communication, Bridge Construction Techniques and Major Road Construction Projects. Topics discussed at the Conference covered a widely varied field. Papers were presented on Deep Strength Asphalt Pavements, Highway Lighting, Skid Resistance Measurement, Developing a Municipal Sports Area, Plan Production Techniques, Involvement of Municipalities and the Public in Freeway Planning, the Department of Youth, Sport, and Recreation, Small Computers and Calculators, Reflective Signing and Delineation Materials, the Road Safety and Traffic Authority, and Traffic Data Collection.

The Board expresses its thanks and appreciation to the Local Government Engineers Association of Victoria for its assistance in planning the Conference, to the contributors of papers or addresses at the Conference, and to the Melbourne Underground Rail Loop Authority for arranging the technical tour for delegates.

## **THE AUSTRALIAN ROAD RESEARCH BOARD**

The Australian Road Research Board was established in 1960, its objectives being to co-ordinate, encourage and arrange further research into problems associated with roads and traffic in Australia such as road safety, cheaper and better road surfaces, traffic flows, planning to meet future needs, and the economics of road transport. Grants are made to the Universities for specific research projects.

Up to ten per cent of the A.R.R.B.'s annual expenditure is borne by the Commonwealth Department of Housing and Construction and the balance is shared by the six State Road Authorities on the percentage basis adopted by the Commonwealth Government in making grants to the States under the Commonwealth Aid Roads legislation.

The Heads of the State Road Authorities are ex-officio members of the Board. Mr. R. E. V. Donaldson who is Deputy Chairman of the Australian Road Research Board attended meetings of the Board on November 14-15, 1973, in Sydney, and on May 23-24, 1974, in Melbourne.

Biennial conferences are held for the presentation and discussions of papers on road research and allied topics. The Board also produces a quarterly journal "Australian Road Research" and publishes special reports on the major research projects.

An advisory Council and a number of specialist committees or panels assist in the planning of the research programme. Some Country Roads Board engineers and scientists acting in an independent capacity, are members of several of these advisory groups as indicated:

Bituminous Surfacing Committee.

Bituminous Surfacing Design and Construction Panel.



Bituminous Surfacing Materials Panel (Mr. H. D. Taskis, Principal Scientific Officer).  
Human Factors Committee.  
Local Government Engineers Committee.  
Pavement Committee (Dr. D. T. Currie, Materials Research Engineer).  
Pavement Design and Performance Panel.  
Pavement Materials and Construction Panel.  
Road Structures Committee (Mr. K. N. Opie, Chief Bridge Engineer).  
Road Transport Planning Committee (Mr. N. S. Guerin, Chief Planning Engineer).  
Metals in Road Structures Panel (Mr. R. S. Gilmour, Metallurgist).  
Traffic Engineering Committee (Mr. R. T. Underwood, Asst. Chief Road Design Engineer).

## VISITS TO MUNICIPALITIES

Since the inception of the Board in 1913, the Board Members have regularly visited municipalities throughout the State.

In a continuing programme, each municipality is visited approximately every six years, enabling the Members to keep up to date with new developments and road conditions and maintain personal contact with councillors and local government officers.

During the year the Board made official visits to 32 municipalities: the Shires of Bet Bet, Buln Buln, Buninyong, Charlton, Cobram, Eltham, Glenelg, Gordon, Kowree, Kyneton, Mclvor, Maffra, Maldon, Marong, Newham and Woodend, Rochester, Strathfieldsaye, Swan Hill, Tambo, Tungamah, Wannon and Werribee and the Cities of Bendigo, Doncaster and Templestowe, Fitzroy, Hawthorn, Moorabbin, St. Kilda, Sandringham, South Melbourne, Swan Hill and Williamstown.

The Board also visited Ballarat City during the year to discuss road developments proposed in the report of the Ballarat Transportation Study.

The Board records its appreciation of the assistance given by all councillors and municipal officers during these visits and extends its thanks to the councils for the hospitality received.

## DEPUTATIONS

The Board is always prepared to receive deputations from municipal councils or other official bodies to discuss matters of common interest. These meetings are a useful channel of communication between the Board and local administration.

During the year the Board received 30 deputations, 28 of these being from municipalities.

Principal topics were the allocation of funds by the Board, works programming and freeway planning.

The Board is appreciative of the time freely given by municipal councillors in bringing matters of local importance to its attention.

## NATIONAL ASSOCIATION OF AUSTRALIAN STATE ROAD AUTHORITIES

The National Association of Australian State Road Authorities (N.A.A.S.R.A.) is an organization of the six State road authorities and the road constructing authority for the territories administered by the Commonwealth Government.

Meetings of the Association are held at six monthly intervals and are attended by the Heads of the seven member authorities.

Representatives of the Commonwealth Department of Transport and the Commonwealth Bureau of Roads also attend the meetings while matters of common interest are discussed.

N.A.A.S.R.A. aims at uniformity of practice in road design and operation and improved road construction methods, publishing the results of its findings in technical manuals. It is a body which collects and disseminates information relating to traffic, the types and standards of roads and road finance. The information is used for the formulation of national road policies.

During the year three meetings of N.A.A.S.R.A. were held, viz.

50th (Annual) Meeting in Sydney on 12th and 13th November 1973, attended by Mr. R. E. V. Donaldson.

Special Meeting in Melbourne on 9th January 1974 to consider the Commonwealth Bureau of Roads Report — "Roads in Australia 1973", attended by the three Board Members.

51st (Intermediate) Meeting in Melbourne on 22nd May 1974, attended by the three Board Members.

Mr. R. E. V. Donaldson and Mr. T. H. Russell attended a general meeting of Highway Ministers in Sydney on 16th November 1973.

Mr. R. E. V. Donaldson also attended special meetings of the Ministers in Sydney on 23rd January 1974 and 19th February 1974 to consider further the Commonwealth Bureau of Roads Report which contained recommendations for the Australian Road Grants legislation to be effective as from 1st July 1974.

N.A.A.S.R.A. is represented on Committees of the Australian Committee on Road Devices, Australian Transport Advisory Council, Metric Conversion Board, Concrete Institute of Australia, and the Standards Association of Australia.

The technical work of the Association is planned and organised by a Principal Technical Committee on which the Board's representative is Mr. W. S. Brake, Chief Engineer.

This Committee is assisted by the following specialist Committees with the Board's representation as indicated:

Advance Planning — Mr. J. H. Pittard, Advance Planning Engineer.

Bridge Engineering — Mr. K. N. Opie, Chief Bridge Engineer.

Computer — Mr. D. Linsten, Engineer-in-Charge, Computer Section.  
Mr. N. J. Smithwick, Data Processing Officer.

Construction and Maintenance Practice — Mr. W. F. Neville, Assistant Chief Works Engineer.

Geometric Road Design — Mr. A. M. Noble, Plans and Surveys Engineer.

Materials Research — Dr. D. T. Currie, Materials Research Engineer.

Plant and Equipment — Mr. G. M. Langham, Chief Mechanical Engineer.

Traffic Engineering — Mr. R. T. Underwood, Assistant Chief Road Design Engineer.

Financial and Administrative matters are considered by the Secretarial and Accounts Committee on which the Board is represented by Mr. N. L. Allanson, Secretary, and Mr. R. G. Cooper, Chief Accountant.

Some additional Committees have been formed to perform specific tasks such as the preparation of publications on the role of roads in the movement of people and goods, and to consider community and environmental problems associated with urban highway proposals, land acquisition procedures, training, legal matters, transportation planning, plant accounts and operating costs of major plant, programme budgeting, roadside development, post office plant in the road reserve, national and inter-regional routes and pavement testing.

The joint work of the State Road Authorities through these Committees ensures co-ordination of effort, uniformity of approach and a pooling of experience in road and bridge planning, design, construction and maintenance.

## CO-OPERATION WITH ARMY RESERVE (C.M.F.)

The Board continued its active sponsorship of Royal Australian Engineer Units of the Army Reserve, namely the Regimental Headquarters and two Squadrons of 22 Construction Regiment. The Commanding Officer of the Regiment is Lt.-Col. G. W. Marshallsea, E.D., the Board's Divisional Engineer, Geelong.

The 1973 camp was held at Benalla during October, where training in range shooting, bridging, and water transport was given to the 150 members of the Board's staff and employees attending for 14 days. The Board's Chairman, Mr. R. E. V. Donaldson, reviewed the Regimental parade.

It is of interest to record that a Committee of Inquiry into the Citizen Military Forces, the Millar Committee, strongly endorsed the supplementary reserve concept and recommended that the formation of additional units be encouraged.

## PERSONNEL

The Board's employment strength as at 30th June, 1974, was as follows:

Salaried Staff		
Professional Engineers		456
Professional Scientists		34
Professional Surveyors		29
Technical Staff		476
Administrative Staff (qualified)		69
Administrative Staff (non-qualified)		360
Administrative Staff (Female non-qualified)		238
Cadets		32
	TOTAL	1,694

Other Personnel	*Field	Depot
Supervisory	299	109
Road Construction and Maintenance	1,677	—
Bridge Construction and Maintenance	108	59
Workshop	—	377
Transport	247	34
Miscellaneous classifications	—	191
	TOTALS	770

\*The above figures do not include employees of contractors or municipal councils engaged in work financed by the Board.

### Recruitment

During the year, 196 new officers were recruited to the Board's salaried staff and 162 officers left the Board due to retirement or resignations.

The buoyant employment situation during the year resulted in fewer applications being received in response to the Board's advertisements for staff. However, in general, satisfactory recruitment was possible except for licensed surveyors and experienced draftsmen.

### Cadetships

The Board's cadetship scheme provides for the payment of all fees, a book allowance and a living allowance. Due to the ready availability of graduates and diplomates in engineering and science, new cadetships in these disciplines were not granted in 1974. Five cadetships in Surveying to commence in the 1974 academic year were awarded by the Board for study at either the University of Melbourne or Royal Melbourne Institute of Technology.

The following table shows the total number of cadets in training for the various courses during the 1974 academic year:

Course	Year of Training				Total
	1st	2nd	3rd	4th	
Civil Engineering	—	4	9	11	24
Mechanical Engineering	—	—	1	—	1
Surveying	1	1	3	—	5
Science	—	—	1	—	1
Totals	1	5	14	11	31

### Apprentices

Twelve apprentices were indentured during the year for training in the trades of Motor Mechanics, Structural Steel and Carpentry and Joinery.

As at 30th June 1974 the total number of apprentices in training was:

Trade	Apprentices
Carpentry and Joinery	4
Electrical Mechanics	1
Fitting and Turning	—
Lithographic Printing	1
Motor Mechanics	41
Painting and Decorating	2
Plumbing and Gas Fitting	1
Structural Steel	4
TOTAL	54



## Retirements

During the year the following personnel retired after substantial service with the Board:

			Years of Service
<b>Salaried Staff</b>			
Allan, J.	Depot Foreman	Geelong Division	27
Clarke, M. R.	Administration Officer	Secretary's Branch	23
Docking, F. W.	Divisional Engineer	Dandenong Division	47
Dolamore, W. H.	Divisional Engineer	Bairnsdale Division	47
Duggan, F. J.	Superintendent of Works	Dandenong Division	34
Edwards, F. S.	Senior Design Engineer	Plans and Surveys Division	20
Fairbanks, C. W.	Clerk of Works	Bridge Sub-branch	22
Harrington, J. F.	Overseer	Horsham Division	22
Humphreys, A. A. F.	Administrative Officer	Estates Section	22
Kirkman, E. W.	Roadmaster	Benalla Division	26
*Leitch, A.	Superintendent of Works	Warrnambool Division	36
Mackenzie, N. P.	Divisional Engineer's Clerk	Horsham Division	24
McKay, T. T.	Clerk of Works	Bendigo Division	27
Munn, R. F.	Roadmaster	Warrnambool Division	35
O'Brien, F. L.	Deputy Estates Officer	Secretary's Branch	24
Pullin, K. T.	Administrative Officer	Works Sub-branch	23
Roberts, M. A.	Senior Draftsman	Benalla Division	24
Sargeant, H. T.	Engineering Asst. (Mech.)	Mechanical Sub-branch	36
Thompson, A. G.	Engineering Assistant	Benalla Division	41
Thompson, D. K. J.	Workshop Foreman	Mechanical Sub-branch	45
Tilley, M. C. (Mrs.)	Senior Clerical Assistant	Mechanical Sub-branch	22
Torrens, E. S.	Research Officer	Advance Planning Section	23
Wilson, A. J.	Overseer	Bairnsdale Division	25
<b>Other Personnel</b>			
Batechelder, H.	Carpenter	Bendigo Division	20
Bradford, C. J.	Patrolman in Charge	Horsham Division	21
Cole, A.	Cook	Warrnambool Division	23
Eccles, H. V.	Plant Operator	Dandenong Division	21
Eddy, F. J.	Traffic Controller	Bendigo Division	23
Grzeskowiak, W.	Tractor Driver	Geelong Division	23
*Haley, G. T.	Storeman	Ballarat Division	23
Hanson, J.	Ganger	Geelong Division	20
Hill, L. D.	Fork-lift Driver	Mechanical Sub-branch	23
Hoppner, W. J.	Ganger	Geelong Division	20
*Jananiec, A.	Skilled Builders' Labourer	Bendigo Division	24
Jutson, W. W.	Machine Float Driver	Mechanical Sub-branch	35
*Kerr, M. A.	Painter	Horsham Division	24
Lea, H. A.	Patrolman in Charge	Bendigo Division	27
Mitchell, D.	Patrolman in Charge	Dandenong Division	20
McNally, J. M.	Patrolman	Warrnambool Division	34
Pontin, E. V.	Fitter	Mechanical Sub-branch	30
*Shkreli, H.	Tradesman's Assistant	Dandenong Division	20
Stevens, L. R.	Patrol Assistant	Benalla Division	26
Turner, L. C.	Construction Worker	Warrnambool Division	21
Walsh, W.	Fitter	Bendigo Division	31
Whelan, L. V.	Patrolman in Charge	Horsham Division	20

\*Deceased.

## Industrial Relations

The Board had to cope with great strains on its finances throughout the year from unprecedented increases in wages and salaries. While the Board cannot control the circumstances that lead to these decisions it does, wherever possible, express its point of view to the appropriate tribunal or authority.

Substantial salary and wages increases occurred during the year —

- in the Municipal Officers (Country Roads Board) Award
- in the State Incremental Payments Scheme
- by the \$15 per week increase from the Metal Industry Award and the flow into many other Awards and State Wages Board Determinations.

The introduction of four weeks' annual leave and an annual leave loading of 17½% also occurred during the year.

The result of the above increases in salaries and wages resulted in an increase in the Board's annual salaries and wages costs of approximately \$6,080,000 or 22.7%. The Board's average work force increased by 184 or 3.9% over the previous year.

The Board sees no signs of any alleviation of this situation in the coming financial year in view of the number of industrial claims still outstanding.

### **Training**

The Board conducted a comprehensive in-service training programme for its staff based on training needs.

Training courses covered road and freeway design, project management, materials research procedures, communication, supervision and human relations.

Job rotation programmes for engineers and draftsmen were continued during the year.

Some of the more important courses attended by the Board's officers were the Australian Administrative Staff College Courses, the Summer School of Business Administration and the Construction Management Course and the Traffic Planning and Control Course at the University of New South Wales.

## **FILMS, PHOTOGRAPHY AND DISPLAYS**

Approximately 35,000 photographic prints were produced during the year as permanent records of road and bridge works, and over 1,800 transparencies were made for lectures and displays. Some 20,000 of these photographs were produced in colour. Flights in light aircraft were made on 13 occasions to obtain aerial photographs of floods to assist in the selection of future road alignments or for illustrations in publications.

Cine films, slides, overhead projectors and other visual aids were used to assist technical conferences, training courses and seminars.

"Sixty Years of Service" was the theme of the Board's display at the 1973 Royal Agricultural Show. A segment of particular interest to the public was a practical demonstration of the testing methods used to determine the skid resistance properties of stone used for road surfacing. Two slide projectors operated by press buttons illustrated the contrasts between early and present-day road conditions and methods of construction. A fifteen minute cine film titled "Wheels of Progress" was produced for the display to illustrate the development of the Board's activities since 1913.

During May 1974, the Board conducted a display at the Melbourne Truck and Bus Show at Brooklyn. The exhibit had two themes of interest to commercial vehicle operators — the advantages of operating on freeways, and an outline of the economics of road vehicle limits study being undertaken by the National Association of Australian State Road Authorities.

## APPENDIX 1

### MILEAGES OF STATE HIGHWAYS, FREEWAYS, FOREST ROADS, AND TOURISTS' ROADS

As at 30th June, 1974

#### STATE HIGHWAYS

NAME	ROUTE	LENGTH (MILES)
BASS	Lang Lang-Inverloch	38.0
BELLARINE	Geelong-Queenscliff	19.8
BONANG	Orbost-N.S.W. border near Delegate	72.0
BORUNG	Dimboola-Charlton	76.7
BURWOOD	Burwood-Ferntree Gully	12.8
CALDER	Melbourne-Mildura	347.6
CANN VALLEY	Cann River-N.S.W. border	28.9
GLENELG	Ballarat-S.A. border near Mt. Gambier	175.9
GOULBURN VALLEY	Eildon-Strathmerton	139.4
HAMILTON	Geelong-Hamilton	144.3
HENTY	Portland-Lascelles	209.6
HUME	Melbourne-N.S.W. border near Albury	153.2
KIEWA VALLEY	Bandiana-Mt. Beauty	48.9
LODDON VALLEY	Bendigo-Kerang	76.8
MAROONDAH	Melbourne-Mansfield	115.5
McIVOR	Heathcote-Bendigo	27.5
MIDLAND	Geelong-Ballarat-Bendigo-Shepparton-Benalla- Mansfield	259.6
	Morwell-Port Welshpool	51.4
MURRAY VALLEY	Corryong-Hattah	462.5
NEPEAN	Melbourne-Portsea	55.4
NORTHERN	Kilmore-Echuca	88.5
OMEO	Bairnsdale-Tallangatta	177.8
OUYEN	Ouyen-S.A. border near Pinnaroo	80.9
OVENS	Wangaratta-Bright	47.4
PRINCES (EAST)	Melbourne-N.S.W. border near Genoa	306.5
PRINCES (WEST)	Melbourne-S.A. border near Mt. Gambier	247.3
PYRENEES	Elphinstone-Ararat	91.9
SOUTH GIPPSLAND	Dandenong-Yarram-Sale	157.9
STURT	Mildura-S.A. border near Renmark	71.1
SUNRAYSIA	Ballarat-Calder Highway	212.0
WARBURTON	Lilydale-Warburton	22.9
WESTERN	Melbourne-Serviceton	242.4
WIMMERA	Apsley-St. Arnaud	136.8

#### FREEWAYS

NAME	SECTION	LENGTH (MILES)
CALDER	Keilor	1.0
	Elphinstone	1.7
FRANKSTON	Frankston-Cranbourne Road to Armstrongs Road	3.6
HUME	Craigieburn to Kalkallo	5.2
	Beveridge	2.0
	Broadford to Tallarook	9.4
	Chiltern	13.2
LOWER YARRA	Princes Freeway to west of Williamstown Road	3.4
MULGRAVE	Springvale Road to South Gippsland Freeway	7.8
PRINCES	Moe to Morwell	10.1
	Lara	15.1
	Laverton	8.1
	Maltby (Werribee)	6.3
	Dartmoor	1.9
SOUTH GIPPSLAND	Whitelaw	2.4
	Mulgrave Freeway to Princes Highway	0.7
TULLAMARINE	Bell Street to Melbourne Airport	7.0
WESTERN	Rockbank	8.3
	Bacchus Marsh	5.2
	Pykes Creek	3.6
	Gordon	5.4



## TOURISTS' ROADS

NAME	MUNICIPALITIES	LENGTH (MILES)
ACHERON WAY	Healesville and Upper Yarra Shires	22.5
ALPINE	Bright and Omeo Shires	52.0
ARTHUR'S SEAT	Flinders Shire	5.4
BOGONG HIGH PLAINS	Bright and Omeo Shires	41.7
CAMERON DRIVE	Gisborne and Newham and Woodend Shires	2.7
DONNA BUANG	Healesville and Upper Yarra Shires	21.8
GIPSY POINT	Orbost Shire	1.5
GRAMPIANS	Ararat, Dundas, and Stawell Shires and Stawell Town	43.2
GREAT OCEAN ROAD	Barrabool, Winchelsea, Otway, Heytesbury and Warrnambool Shires	132.2
MALLACOOTA	Orbost Shire	15.0
MOUNT ABRUPT	Ararat and Mount Rouse Shires	15.4
MOUNT BUFFALO	Bright Shire	25.0
MOUNT BULLER	Mansfield Shire	15.7
MOUNT DANDENONG	Sherbrooke and Lillydale Shires	13.7
MOUNT VICTORY	Arapiles, Stawell and Wimmera Shires	19.1
MARYSVILLE- WOODS POINT	Healesville Shire	9.2
OTWAY LIGHTHOUSE	Otway Shire	8.0
PHILLIP ISLAND	Bass and Phillip Island Shires	15.1
SILVERBAND	Stawell Shire	5.7
SYDENHAM INLET	Orbost Shire	13.5
WARTOOK	Wimmera Shire	2.2
WILSON'S PROMONTORY	South Gippsland Shire	19.3

## FOREST ROADS

NAME	MUNICIPALITIES	LENGTH (MILES)
BAIRNSDALE-DARGO	Avon and Bairnsdale Shires	12.9
BEALIBA-MOLIAGUL	Bet Bet Shire	5.6
BEECH FOREST- MT. SABINE	Otway Shire	7.8
BENAMBRA-CORRYONG	Omeo, Tallangatta, and Upper Murray Shires	47.7
BENAMBRA-LIMESTONE	Omeo Shire	8.9
BENDOC-ORBOST	Orbost Shire	13.0
BROOKVILLE	Omeo Shire	9.9
BRUTHEN-BUCHAN	Tambo Shire	22.7
BUCHAN-ENSAY	Tambo Shire	12.3
BULLUMWAAL- TABBERABBERA	Bairnsdale Shire	18.8
CARRAJUNG-WOODSIDE	Alberton Shire	11.0
DARGO	Avon Shire	46.5
DEAN MARSH-LORNE	Winchelsea Shire	14.9
DRUMMOND-VAUGHAN	Daylesford and Glenlyon and Newstead Shires	13.0
EPSOM-FOSTERVILLE	Huntly Shire	13.2
FORREST-APOLLO BAY	Otway Shire	13.9
GREENDALE-TRENTHAM	Ballan and Kyneton Shires	14.8
HEYFIELD-JAMIESON	Mansfield and Maffra Shires	90.6
INGLEWOOD-RHEOLA	Korona Shire	10.8
KIMBOLTON	Strathfieldsaye Shire	8.4
LAVERS HILL-COBDEN	Heytesbury and Otway Shires	29.2
MEREDITH-STEIGLITZ- MAUDE	Bannockburn Shire	12.9
MURRUNGOWER	Orbost Shire	13.2
PORTLAND-NELSON	Portland Shire	24.0
RED KNOB	Tambo Shire	4.2
TATONG-TOLMIE	Benalla Shire	22.7
WALHALLA	Narracan, Mansfield and Upper Yarra Shires	68.8
WARBURTON-WOODS POINT	Healesville, Upper Yarra and Mansfield Shires	64.7
WARROWITUE	Mclvor Shire	10.2

## STATE HIGHWAYS AND FREEWAYS

### Significant Works Completed During Financial Year 1973/74

#### BASS HIGHWAY

BASS SHIRE Widening and realignment of 1.8 miles to provide a sealed pavement 24 feet wide south of Bass.

#### BELLARINE HIGHWAY

BELLARINE SHIRE Construction of 1.6 miles between Moolap and Leopold to provide dual carriageways each 24 feet wide.

#### CALDER HIGHWAY

BULLA SHIRE Provision of 1.5 miles of climbing lane at Gap Hill. Reconstruction of 2.2 miles north of Corkscrew Hill. Reconstruction and widening of 0.6 mile at Adeneys Hill.

KEILOR CITY Provision of 0.2 mile of a passing lane at St. Albans Road intersection.

KORONG SHIRE Reconstruction of 3.3 miles between Inglewood and Wedderburn to provide a sealed pavement 24 feet wide.

MILDURA SHIRE Reconstruction of 4.0 miles north of Hattah to provide a sealed pavement 24 feet wide.

WALPEUP SHIRE Reconstruction of 2.3 miles north of Ouyen to provide a sealed pavement 24 feet wide.



*Reconstructed section of the Calder Highway north of Ouyen.*

#### CANN VALLEY HIGHWAY

ORBOST SHIRE Reconstruction of 1.7 miles north of Weeragua to Chandlers Creek to provide a sealed pavement 20 feet wide.

#### GLENELG HIGHWAY

DUNDAS SHIRE Reconstruction of 3.5 miles between Bochara and Wannan to provide a sealed pavement 24 feet wide.



**GLENELG SHIRE**

Reconstruction of 2.0 miles at Green Lagoon, west of Casterton, to provide a sealed pavement 24 feet wide.



*Reconstructed section of the Glenelg Highway at Green Lagoon.*

**GOULBURN VALLEY HIGHWAY**

**ALEXANDRA SHIRE**

Reconstruction of 0.6 mile in Alexandra township to provide 0.3 mile of sealed pavement 42 feet wide and 0.3 mile of sealed pavement 24 feet wide.

**NUMURKAH SHIRE**

Reconstruction of 3.1 miles between Numurkah and Strathmerton to provide a sealed pavement 18 feet wide.

**SHEPPARTON SHIRE**

Reconstruction of 1.5 miles south of Shepparton to provide a sealed pavement 24 feet wide.

**YEA SHIRE**

Construction of a reinforced concrete bridge 160 feet long and 28 feet between kerbs over Home Creek, east of Molesworth township.

**HAMILTON HIGHWAY**

**HAMPDEN SHIRE**

Reconstruction of 3.4 miles east of Lismore to provide a sealed pavement 24 feet wide.



*Hamilton Highway—reconstructed east of Lismore.*



LEIGH SHIRE Reconstruction of 5.2 miles west of Inverleigh to provide a sealed pavement 24 feet wide.

MOUNT ROUSE SHIRE Reconstruction of .61 miles west of Peshurst to provide a sealed pavement 24 feet wide.

#### **HENTY HIGHWAY**

KARKAROOC SHIRE Reconstruction of 2.1 miles south of Beulah to provide a sealed pavement 24 feet wide.

PORTLAND SHIRE Reconstruction of 6.0 miles at Condah to provide a sealed pavement 24 feet wide.

#### **KIEWA VALLEY HIGHWAY**

BRIGHT SHIRE Construction of a new reinforced concrete bridge 106 feet long and 28 feet between kerbs plus a 5 feet wide footway over the West Kiewa River at Mt. Beauty.

#### **MAROONDAH HIGHWAY**

ALEXANDRA SHIRE Reconstruction of 0.9 mile between Buxton and Tagerty to provide a sealed pavement 24 feet wide.

BOX HILL CITY Reconstruction of 1.1 miles of southern carriageway between Court Street and Station Street.

#### **MIDLAND HIGHWAY**

CASTLEMAINE SHIRE Widening to 54 feet and redecking the bridge over Forest Creek at Castlemaine to provide 4 traffic lanes and two footways.

HUNTLY SHIRE Reconstruction of 1.6 miles between Bendigo and Goornong to provide a sealed pavement 24 feet wide.

MORWELL SHIRE Construction of 6.7 miles of new road between Churchill and south of Yinnar to provide a sealed pavement 24 feet wide.



*New construction on the Midland Highway deviation south of Morwell.*

NEWSTEAD SHIRE Redecking and strengthening a 262 feet long timber bridge over the Loddon River at Guildford.

## MURRAY VALLEY HIGHWAY

COHUNA SHIRE	Reconstruction of 0.6 mile in the township of Cohuna to provide a sealed pavement 24 feet wide.
COBRAM SHIRE	Reconstruction of 0.7 mile east of Cobram to provide a sealed pavement 24 feet wide.
KERANG SHIRE	Reconstruction of 1.5 miles north of Kerang to provide a sealed pavement 24 feet wide.
RUTHERGLEN SHIRE	Reconstruction of 1.2 miles west of Rutherglen to provide a sealed pavement 20 feet wide.
WODONGA CITY	Reconstruction of 0.3 mile over the Kiewa River Flats to provide a sealed pavement 24 feet wide. Widening two reinforced concrete bridges from 22 feet to 28 feet between kerbs on the Kiewa River Flats.
YARRAWONGA SHIRE	Construction of a reinforced concrete bridge 142 feet long and 28 feet between kerbs, known as the "Parolas" Bridge, over the Ovens River Floodway.

## NEPEAN HIGHWAY

BRIGHTON CITY	Reconstruction of the Hawthorn Road intersection.
---------------	---

## NORTHERN HIGHWAY

PYALONG SHIRE	Construction of 3.5 miles on a new alignment south of Pyalong to provide a sealed pavement 24 feet wide.
---------------	--



*Reconstructed section of the Northern Highway south of Pyalong*

## OMEQ HIGHWAY

TALLANGATTA SHIRE	Reconstruction of 1.9 miles north of Tallandoon to provide a sealed pavement 22 feet wide.
TAMBO SHIRE	Reconstruction of 1.4 miles between Wiseleigh and Bruthen to provide a sealed pavement 24 feet wide.

## PRINCES FREEWAY

CORIO SHIRE	Construction of an interchange at Avalon, including an overpass structure 270 feet long and 28 feet wide between kerbs to carry local traffic over the freeway.
-------------	---



## **PRINCES HIGHWAY EAST**

BERWICK CITY	Extension of 0.4 mile of a climbing lane east of Berwick on the south side of the highway with widening on the north side.
NARRACAN SHIRE	Construction of 0.8 mile of dual carriageways each 34 feet wide through Yarragon township.
ORBOST SHIRE	Reconstruction of 1.7 miles west of Wingan River to provide a sealed pavement 24 feet wide. Reconstruction of 1.9 miles east of Murrungowar to provide a sealed pavement 24 feet wide.
TAMBO SHIRE	Improvement of the intersection with Lake Tyers Beach Road.

## **PRINCES HIGHWAY WEST**

FOOTSCRAY CITY	Reconstruction of the bridge over the railway and 0.7 mile of general improvements to the highway between Gordon Street and Geelong Street.
----------------	---

## **PYRENEES HIGHWAY**

TULLAROOP AND AVOCA SHIRES	Reconstruction of 1.2 miles at Bung Bong to provide a sealed pavement 24 feet wide.
-------------------------------	---

## **SOUTH GIPPSLAND HIGHWAY**

KORUMBURRA SHIRE	Reconstruction of 1.0 mile east of Korumburra to provide a sealed pavement 24 feet wide.
------------------	--



*Reconstructed section of the South Gippsland Highway east of Korumburra.*

WOORAYL SHIRE	Reconstruction of the intersection with Nerrena Road in Leongatha township.
---------------	---



## **SUNRAYSIA HIGHWAY**

AVOCA SHIRE	Reconstruction of 0.8 mile between Bet Bet Creek and Lamplough to provide a sealed pavement 24 feet wide.
BALLARAT SHIRE	Widening the existing junction with Quarry Road at Miners Rest.
BIRCHIP SHIRE	Resheeting and widening 1.5 miles west of Birchip to provide a sealed pavement 20 feet wide.

## **WESTERN HIGHWAY**

RIPON SHIRE	Reconstruction of 1.2 miles through Beaufort township to provide a sealed pavement 24 feet wide.
-------------	--

## **WIMMERA HIGHWAY**

KARA KARA SHIRE	Resheeting and widening of 4.5 miles east of Marnoo to provide a sealed pavement 24 feet wide.
-----------------	--

## TOURISTS' ROADS AND FOREST ROADS

### Significant Works Completed During Financial Year 1973/74

#### TOURISTS' ROADS

##### ALPINE ROAD

Construction of 0.2 mile of approaches to the bridge over Livingstone Creek and reconstruction of the junction with Swifts Creek-Omeo Road.

##### BOGONG HIGH PLAINS ROAD

Construction of 2.1 miles to provide a sealed pavement 25 feet wide between the Gate House and Crankie Charlie.  
Widening of the bridge over the Tail Race Channel at Mt. Beauty from 18 to 26 feet between kerbs.



*Bogong High Plains Road—bridge over Tail Race Channel, Mt. Beauty.*

##### GREAT OCEAN ROAD

Reconstruction of 0.9 mile from Coalmine Creek to Clarks Slip to provide a sealed pavement 24 feet wide.  
Reconstruction of 4.3 miles from Ford River to Johanna Road to provide a sealed pavement 20 feet wide.

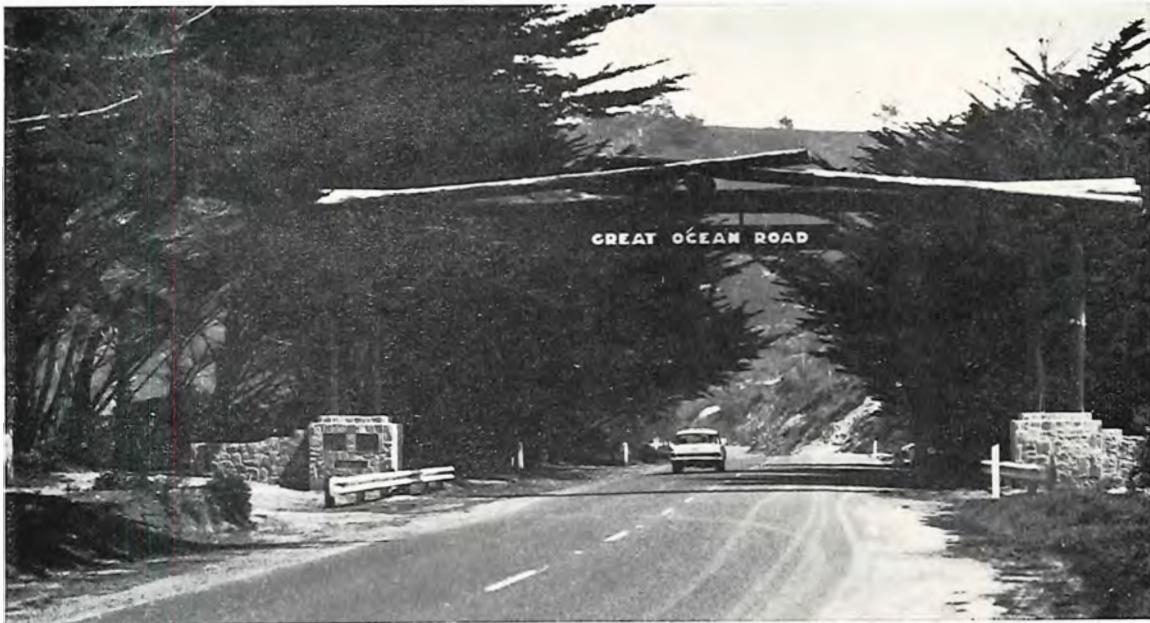

*Great Ocean Road—reconstructed between Coalmine Creek and Clarks Slip.*

MT. BUFFALO ROAD

Reconstruction of 0.5 mile between Cathedral and Cresta to provide a sealed pavement 24 feet wide.

PHILLIP ISLAND ROAD

Widening and reconstruction of 1.1 miles from the Rhyll turnoff to the Koala Park Reserve.

**FOREST ROADS**

DARGO ROAD

Reconstruction of 1.6 miles at Waterford to provide a sealed pavement 18 feet wide.

WALHALLA ROAD

Reconstruction and realignment of 0.5 mile of approaches to the proposed new reinforced concrete bridge over the Latrobe River, and improvements to the intersection with Old Sale Road.



## MAIN ROADS

## Significant Works Completed During Financial Year 1973/74

## BAIRNSDALE DIVISION

OMEEO SHIRE Day Avenue — Construction of a new bridge 150 feet long and 28 feet wide between kerbs over Livingstone Creek, west of Omeo.

Ensay-Doctors Flat Road — Widening of 2.0 miles between Ensay South and Doctors Flat to provide a sealed pavement 12 feet wide.

ORBOST SHIRE Combienbar Road — Reconstruction of 2.1 miles at Club Terrace to provide a sealed pavement 18 feet wide.

TAMBO SHIRE Bruthen-Buchan Road — Construction of 0.3 mile of approaches to Ti Tree Creek Bridge to provide a sealed pavement 20 feet wide.

Metung Road — Construction of 1.8 miles at Metung to provide a sealed pavement 20 feet wide.

## BALLARAT DIVISION

BALLAN SHIRE Ballan-Meredith Road — Reconstruction of 0.6 mile at Morrisons to provide a sealed pavement 20 feet wide.

DAYLESFORD AND GLENLYON SHIRE Ballan Road — Reconstruction of 0.9 mile between Dwyer's Mill and Leonard's Hill to provide a sealed pavement 22 feet wide.

GISBORNE SHIRE Gisborne-Kilmore Road — Reconstruction of 0.6 mile north-east of Gisborne to provide a sealed pavement 24 feet wide.

GRENVILLE SHIRE Cape Clear-Rokewood Road — Reconstruction of 1.3 miles at Tillabarook to provide a sealed pavement 20 feet wide.



*Reconstructed section of Cape Clear—Rokewood Road, Shire of Grenville.*

NEWSTEAD SHIRE Creswick Road — Reconstruction of 0.4 mile at Campbelltown to provide a sealed pavement 22 feet wide.

ROMSEY SHIRE Melbourne-Lancefield Road — Reconstruction of 1.3 miles near Clarkefield to provide a sealed pavement 24 feet wide.

TALBOT AND CLUNES SHIRE Reconstruction of 0.9 mile at Kilkenny Creek near Clunes to provide a sealed pavement 24 feet wide.

### **BENALLA DIVISION**

MANSFIELD SHIRE Mansfield Road — Reconstruction of 0.6 mile between Mansfield and Merrijig to provide a sealed pavement 24 feet wide.

Mansfield-Whitfield Road — Reconstruction of 2.3 miles near Tolmie to provide a sealed pavement 20 feet wide.

MYRTLEFORD SHIRE Happy Valley Road — Reconstruction of 1.3 miles east of Myrtleford to provide a sealed pavement 20 feet wide.



*Reconstructed section of Happy Valley Road, Shire of Myrtleford.*

TALLANGATTA SHIRE Murray Valley Road — Reconstruction of 1.0 mile north of Bethanga Bridge to provide a sealed pavement 22 feet wide.

YEA SHIRE Whittlesea-Yea Road — Reconstruction of 1.7 miles south of Yea to provide a sealed pavement 22 feet wide.

### **BENDIGO DIVISION**

DEAKIN SHIRE Kyabram-Tongala Road — Reconstruction of 2.3 miles east of the Echuca-Kyabram Road to provide a sealed pavement 22 feet wide.



**GORDON SHIRE**

Boort-Kerang Road—Reconstruction of 2.0 miles south of the boundary with Kerang Shire to provide a sealed pavement 22 feet wide.



*Reconstructed section of Boort-Kerang Road, Shire of Gordon.*

**DANDENONG DIVISION**

**BERWICK SHIRE**

Beaconsfield-Emerald Road — Deviation of 5.7 miles (generally via Ladd Road and Paternoster Road) to provide a sealed pavement 22 feet wide.



*Deviation of Beaconsfield-Emerald Road, Shire of Berwick.*

**DANDENONG CITY**

Cheltenham Road — Reconstruction of intersection of Foster Street and Thomas Street.



ELTHAM SHIRE	<p>Eltham-Yarra Glen Road — Construction of 0.4 mile of the Cressy Street-Bolton Street duplication to provide dual carriageways each 32 feet wide.</p> <p>Heidelberg-Kinglake Road—Reconstruction of 0.4 mile between Hurstbridge and Wattle Glen, to provide a sealed pavement 30 feet wide.</p>
FRANKSTON SHIRE	Dandenong-Frankston Road — Construction of 1.6 miles through Carrum Downs to provide dual carriageways each 24 feet wide.
HASTINGS SHIRE	Baxter-Tooradin Road — Reconstruction of 1.2 miles to provide a sealed pavement 24 feet wide.
HEALESVILLE SHIRE	Eltham-Yarra Glen Road — Reconstruction of 1.0 mile in the vicinity of the Christmas Hills, to provide a sealed pavement 20 feet wide.
KNOX CITY	<p>High Street Road—Construction of 0.9 mile to provide dual carriageways each 32 feet wide.</p> <p>Stud Road — Construction of dual carriageways between Boronia Road and the Burwood Highway each 33 feet wide.</p>
NUNAWADING CITY	Canterbury Road — Construction of 0.7 mile of dual carriageways between View Road and Heatherdale Road each 33 feet wide.
SPRINGVALE CITY	Cheltenham Road — Construction of 1.0 mile of dual carriageways 33 feet wide between Springvale Road and Corrigan Road.
WAVERLEY CITY	<p>Doncaster-Mordialloc Road — Construction of 0.2 mile of dual carriageways south of Highbury Road each 45 feet wide.</p> <p>Springvale Road — Construction of 1.0 mile of dual carriageways between High Street and Waverley Road each 33 feet wide.</p>

## GEELONG DIVISION

BACCHUS MARSH SHIRE	Bacchus Marsh Road — Reconstruction of 0.7 mile in Bacchus Marsh township to provide a sealed pavement 42 feet wide.
BELLARINE SHIRE	Geelong-Portarlington Road — Construction of 1.1 miles of dual carriageways each 24 feet wide in East Geelong.

## HORSHAM DIVISION

DONALD SHIRE	Marnoo-Donald Road — Reconstruction of 1.6 miles east of Banyena to provide a sealed pavement 20 feet wide.
DUNMUNKLE SHIRE	Donald-Minyip Road — Reconstruction of 0.1 mile including sealing of Main Street in Minyip township to provide an overall sealed width of 72 feet.
WYCHEPROOF SHIRE	<p>Birchip-Wycheproof Road — Reconstruction of 2.4 miles west of Wycheproof to provide a sealed pavement 22 feet wide.</p> <p>Sea Lake-Swan Hill Road — Maintenance resealing in Sea Lake township and for 6 miles east of Sea Lake to provide a sealed pavement 20 feet wide.</p>

## METROPOLITAN DIVISION

### NORTHCOTE CITY

Heidelberg-Eltham Road — Improvements at the Chandler Highway and Grange Road intersections.



*Heidelberg-Eltham Road at the intersection with Chandler Highway and Grange Road, City of Northcote.*

## TRARALGON DIVISION

- |                       |   |
|-----------------------|---|
| ALBERTON SHIRE        | Yarram-Morwell Road — Construction of a reinforced concrete bridge over Stony Creek, 150 feet long and 28 feet between kerbs.<br>Yarram-Traralgon Road — Reconstruction of 1.7 miles north of Yarram including a 3 cell armco culvert to provide a sealed pavement 12 and 14 feet wide. |
| BULN BULN SHIRE       | Drouin-Poowong Road — Reconstruction of 1.4 miles at Drouin South to provide a sealed pavement 22 feet wide.  |
| KORUMBURRA SHIRE      | Korumburra-Wonthaggi Road and Bena-Konwak and McCraws Road — Reconstruction of the intersection of these roads to provide widened pavements and left-turn lanes.  |
| MIRBOO SHIRE          | Mirboo North-Thorpdale Road — Reconstruction of 1.6 miles of approaches to the bridge over Little Morwell River to provide a sealed pavement 24 feet wide.  |
| MORWELL SHIRE         | Jeeralang West Road — Reconstruction of 1.4 miles south of Jeeralang Junction to provide a sealed pavement 21 feet wide.  |
| SOUTH GIPPSLAND SHIRE | Fish Creek-Foster Road — Installation of a 16 feet diameter culvert under the Fish Creek-Foster Road at Foster.   |
| TRARALGON SHIRE       | Traralgon West Road — Reconstruction of 0.5 mile west of Traralgon to provide a sealed pavement 24 feet wide.   |

- WARRAGUL SHIRE      Warragul-Korumburra Road — Reconstruction of 1.0 mile north of Strezlecki to provide a sealed pavement 20 feet wide.
- Warragul-Leongatha Road — Reconstruction of 1.2 miles north of Seaview to provide a sealed pavement 18 feet wide together with the installation of a 13'6" long x 9'6" wide armco pipearch.
- WOORAYL SHIRE      Inverloch-Leongatha Road — Reconstruction of 1.5 miles south-west of Leongatha with minor realignment to provide a sealed pavement 22 feet wide.
- Lower Tarwin Road — Reconstruction of 1.3 miles east of Inverloch with minor realignment to provide a sealed pavement 22 feet wide.

**WARRNAMBOOL DIVISION**

- HAMPDEN SHIRE      Darlington Road — Reconstruction of 2.9 miles north-west of Camperdown to provide a sealed pavement 24 feet wide.
- HEYTESBURY SHIRE    Cobden-Stoneyford Road — Reconstruction of 1.3 miles east of Cobden to provide a sealed pavement 22 feet wide.
- MINHAMITE SHIRE    Woolsthorpe-Heywood Road — Reconstruction of 1.9 miles north-west of Woolsthorpe to provide a sealed pavement 20 feet wide.
- MORTLAKE SHIRE      Mortlake-Ararat Road — Reconstruction of 4.9 miles north of Mortlake to provide a sealed pavement 22 feet wide.
- PORTLAND SHIRE      Woolsthorpe-Heywood Road — Reconstruction of 1.7 miles east of Heywood to provide a sealed pavement 22 feet wide.



*Reconstructed section of Woolsthorpe-Heywood Road, Shire of Portland.*



UNCLASSIFIED ROADS

Significant Works Completed During Financial Year 1973/74

BALLARAT DIVISION

AVOCA SHIRE Navarre-Wattle Creek Road — Construction of a reinforced concrete bridge 80 feet long and 22 feet 6 inches between kerbs over Wattle Creek.



*Bridge over Wattle Creek, Navarre-Wattle Creek Road, Shire of Avoca.*

BALLAARAT CITY Eureka Street — Reconstruction between Otway Street and Fussell Street, Ballarat East, to provide a sealed pavement 40 feet wide.

BALLARAT SHIRE Norman Street — Reconstruction between the Midland Highway and Forest Street, Wendouree, to provide a sealed pavement 24 feet wide.

CRESWICK SHIRE Creswick-Dean Road — Reconstruction of 0.8 mile at Creswick to provide a sealed pavement 22 feet and 20 feet wide.



*Reconstructed section of Creswick-Dean Road, Shire of Creswick.*



- NEWSTEAD SHIRE Cemetery Road — Installation of a 10 feet by 9 feet reinforced concrete box culvert at the Muckleford Creek crossing in Newstead.
- RIPON SHIRE Beaufort-Elmhurst Road — Reconstruction of 1.1 miles at Raglan to provide a sealed pavement 20 feet wide.
- TULLAROOP SHIRE Moolort-Barringhup Road — Construction of a reinforced concrete bridge 80 feet long and 24 feet between kerbs over the Castlemaine-Dunolly railway line at Moolort.



*Moolort-Barringhup Road, Shire of Tullaroop. Bridge over railway at Moolort.*

## **BENALLA DIVISION**

- ALEXANDRA SHIRE Eildon-Jamieson Road — Reconstruction of 1.5 miles east of Eildon to provide a sealed pavement 20 feet wide.
- BENALLA SHIRE Devenish-Wangaratta Road — Reconstruction of 2.6 miles north of Thoona to provide a sealed pavement 12 feet wide.



*Reconstructed section of Devenish-Wangaratta Road north of Thoona, Shire of Benalla.*

MANSFIELD SHIRE	Hutchinsons Road — Reconstruction of 2.0 miles along the frontage to Lake Eildon at Bonnie Doon to provide a sealed pavement 18 feet wide.
OXLEY SHIRE	Benalla-Whitfield Road — Reconstruction of 2.1 miles north of Myrree to provide a sealed pavement 18 feet wide.
WANGARATTA CITY	Ryley Street, Wangaratta — Construction of parking lanes on the Hume Highway in Wangaratta.
WANGARATTA SHIRE	Boweya Road — Reconstruction of 2.0 miles east of Boweya to provide a sealed pavement 18 feet wide.
YEA SHIRE	Ghin Ghin Road — Reconstruction of 1.5 miles to provide a sealed pavement 18 feet wide.

#### **BENDIGO DIVISION**

DEAKIN SHIRE	Everards Road — Reconstruction of 2.1 miles north of Mt. Scobie to provide a sealed pavement 22 feet wide. Sinclair Road — Reconstruction of 2.0 miles to provide a sealed pavement 22 feet wide.
KERANG SHIRE	Quambatook-Boort Road — Reconstruction of 1.2 miles south-east of Oakvale to provide a sealed pavement 20 feet wide.

#### **DANDENONG DIVISION**

CROYDON CITY	Maroondah Highway Service Road — Reconstruction between Kent Avenue and Barina Court, and between Warriem Road and the Croydon Golf Links to provide a sealed pavement 22 feet wide.
FLINDERS SHIRE	Latrobe Parade — Construction between Stawell Street and Burrell Road, Dromana, to provide a sealed pavement 24 feet wide.
HASTINGS SHIRE	Tulum Road — Reconstruction from Balnarring Beach to the coast, to provide a sealed pavement 20 feet wide.
KNOX CITY	Forest Road — Reconstruction between Doysal Avenue and Hutton Avenue, Ferntree Gully, to provide a sealed pavement 36 feet wide.
LILLYDALE SHIRE	Birmingham Road — Reconstruction between Edinburgh Road and Hull Road, Lilydale, to provide a sealed pavement 18 feet wide.
MORNINGTON SHIRE	Esplanade — Reconstruction to provide a sealed pavement 30 feet wide.
NUNAWADING CITY	Highbury Road — Extension of reconstruction of 1.1 miles between Blackburn Road and Springvale Road to provide a sealed pavement 36 feet wide.
SPRINGVALE CITY	Chapel Road — Reconstruction between Cheltenham Road and Hutton Road, Keysborough, to provide a sealed pavement 24 feet wide.
WAVERLEY CITY	Blackburn Road — Construction of dual carriageways between Meadow Court and Lemont Avenue, Mount Waverley, each 33 feet wide.

#### **GEELONG DIVISION**

CORIO SHIRE AND GEELONG CITY	Thompsons Road — Widening and resurfacing 1.1 miles from Victoria Street to the Midland Highway to provide a sealed pavement 40 feet wide.
---------------------------------	--



## **HORSHAM DIVISION**

DONALD SHIRE	Massey-Bangerang Road — Reconstruction of 1.9 miles to provide a sealed pavement 12 feet wide. Steep Hills Road — Reconstruction of 2.3 miles to provide a sealed pavement 12 feet wide.
DUNMUNKLE SHIRE	Minyip-Banyera Road — Reconstruction of 4.0 miles to provide a sealed pavement 12 feet wide.
HORSHAM CITY	Lynott Street — Reconstruction of 0.5 mile between Wawunna Road and Albert Street to provide a sealed pavement 40 feet wide.
KARA KARA SHIRE	Cope Cope-Marnoo East Road — Reconstruction of 3.4 miles north from the Banyera Road to provide a sealed pavement 16 feet wide.
KOWREE SHIRE	Harrow-Goroke Road — Reconstruction of 4.4 miles to provide a sealed pavement 12 feet wide.
LOWAN SHIRE	Nhill-Murrayville Road — Reconstruction of 3.0 miles to provide a sealed pavement 22 feet wide.
MILDURA CITY	Ranfurly Way — Widening of 0.9 mile to provide a sealed pavement 24 feet wide.
MILDURA SHIRE	Kempe Road — Construction of 5.2 miles west of Mildura near the South Australian border to provide a sealed pavement 18 feet wide. Benetook Avenue — Reconstruction of 2.0 miles and widening of 1.8 miles between Dow Avenue and Twentieth Street, Mildura, to provide a sealed pavement 20 feet wide.
STAWELL SHIRE	Glenorchy-Donald Road — Reconstruction of 1.4 miles to provide a sealed pavement 12 feet wide. Great Western-Red Bend Road — Construction of a reinforced concrete bridge 105 feet long and 28 feet between kerbs.

## **METROPOLITAN DIVISION**

BROADMEADOWS CITY	Mahoneys Road — Duplication of pavement from the Hume Highway to Riviera Court.
-------------------	---

## **TRARALGON DIVISION**

ALBERTON SHIRE	Jack River Valley Road — Construction of 0.4 mile of approaches and a reinforced concrete bridge 100 feet long and 24 feet between kerbs over Jack River at Alberton West.
KORUMBURRA SHIRE	Shellcotts Road — Reconstruction of 1.5 miles to provide a gravel pavement 22 feet wide.
WARRAGUL SHIRE	Bull Swamp Road — Reconstruction of 1.5 miles at Bona Vista to provide a sealed pavement 20 feet wide. North Road — Reconstruction of 0.6 mile to provide a sealed pavement 36 feet wide. Old Telegraph West Road — Reconstruction of 1.4 miles to provide a sealed pavement 22 feet wide.
WOORAYL SHIRE	Central Road — Construction of reinforced concrete bridge 20 feet between kerbs over the Tarwin River at Tarwin East. Tarwin Lower-Waratah Road — Reconstruction of 0.9 mile to provide a sealed pavement 22 feet wide.

**WARRNAMBOOL DIVISION**

**BELFAST SHIRE**

St. Helens Road — Construction of a bridge 60 feet long and 24.5 feet between kerbs over Shaw River.



*St. Helens Road bridge over Shaw River, Shire of Belfast.*

**HEYTESBURY SHIRE**

Cooriemungle Road — Reconstruction of 1.5 miles to provide a sealed pavement 20 feet wide.

Timboon-Colac Road — Reconstruction of 1.4 miles to provide a sealed pavement 20 feet wide.

Williams Road — Reconstruction of 1.0 mile to provide a sealed pavement 20 feet wide.

**WANNON SHIRE**

Coleraine-Nareen-Mooree Road — Construction of a bridge 176 feet long and 26 feet between kerbs over the Glenelg River and a bridge 35 feet long and 26 feet between kerbs over Sugarloaf Creek.

## SPECIAL PROJECTS FINANCED FROM THE ROADS (SPECIAL PROJECTS) FUND

### Details of Special Projects on which Work was Carried Out During the Year

Project No.	Project	Length (Miles)	Progress of Work
17	<b>Hume Freeway</b> — Construction of a four-lane freeway from south of Wallan to north of Broadford.	21.3	Work continued over the entire length during the year.
29	<b>Mornington Peninsula Freeway</b> — Construction of a four-lane freeway from the Nepean Highway near Palmerston Avenue, Dromana, to Eastbourne Road.	5.0	Work was completed on the through carriageways, which were opened to traffic in December 1973. The construction of an overpass structure at Kangerong Avenue continued.
30	<b>Western Freeway</b> — Pentland Hills section, including a by-pass of Myrning.	7.0	The construction of 3.5 miles west from Bacchus Marsh was completed, and work commenced on 3.5 miles to by-pass Myrning to the south.



## APPENDIX 7

### MOTOR REGISTRATIONS

Registrations under the Motor Car Act during the year 1973/74 totalled 1,908,199, an increase of 7.1% over the total for the previous year.

Vehicle	Financial Year 1972/73		Financial Year 1973/74		Increase	Decrease
<b>Private</b>						
New	113,031		126,282			
Secondhand:						
Re-registered	42,731		46,957			
Renewed	1,148,432		1,222,661			
		1,304,194		1,395,900	91,706	
<b>Commercial and Hire</b>						
New	17,040		17,654			
Secondhand:						
Re-registered	5,135		5,679			
Renewed	115,935		121,734			
		138,110		145,067	6,957	
<b>Primary Producers' Trucks and Tractors</b>						
New	4,074		4,661			
Secondhand:						
Re-registered	3,821		4,349			
Renewed	80,154		79,136			
		88,049 +		88,146 *	97	
<b>Licences under the Motor Omnibus Act</b>		704		764	60	
<b>Trailers</b>		209,748		232,616	22,868	
<b>Motor Cycles</b>		40,735		45,706	4,971	
<b>TOTALS</b>		1,781,540		1,908,199	126,659	

+ Includes 45,785 no-fee tractors.

\* Includes 45,020 no-fee tractors.

## APPENDIX 8

### COUNTRY ROADS BOARD Statement of Receipts and Payments (to Nearest Dollar) for Year Ended 30th June 1974

	Country Roads Board Fund		Loan Funds	Commonwealth Aid Roads Act 1969				C'wealth T. & R.S.I. Trust A/c			Total
	Act 6229	Act 6222 Rd. Mtce. A/c		Sec. 4(1)	Sec. 4(2)	Sec. 4(3)	Sec. 4(4)				
<b>RECEIPTS</b>	\$	\$	\$	\$	\$	\$	\$	\$	\$	\$	
Balance as at 1st July 1973	1,895,804	..	..	..	..	..	..	..	..	1,895,804	
<i>Motor Car Act 1958 (No. 6325)</i>											
Motor Car Registration Fees	38,162,430	..	..	..	..	..	..	..	..	..	
Additional Registration Fees	2,726,256	..	..	..	..	..	..	..	..	..	
Drivers' Licence Fees	911,871	..	..	..	..	..	..	..	..	..	
Drivers' Licence Testing Fees	548,481	..	..	..	..	..	..	..	..	..	
Trailer Registration Fees	964,821	..	..	..	..	..	..	..	..	..	
Examiners' Licence Fees	7,524	..	..	..	..	..	..	..	..	..	
Sale of Log Books	10,713	..	..	..	..	..	..	..	..	..	
Motor Driving Instructors' Licence— Appointment and Testing Fees	2,930	..	..	..	..	..	..	..	..	..	
Motor Driving Instructors' Licence Fees	5,631	..	..	..	..	..	..	..	..	..	
	43,340,657	..	..	..	..	..	..	..	..	..	
Less Cost of Collection	5,803,183	..	..	..	..	..	..	..	..	..	
	37,537,474	..	..	..	..	..	..	..	..	37,537,474	
Municipalities Contributions— Permanent Works — Main Roads Maintenance Works — Main Roads	128,646 2,006,888	..	..	..	..	..	..	..	..	2,135,534	
	2,135,534	..	..	..	..	..	..	..	..	2,135,534	
<i>Commercial Goods Vehicles Act No. 6222</i>	..	10,358,794	..	..	..	..	..	..	..	10,358,794	
<i>Public Works and Services Act No. 8517</i>	568,162	..	..	..	..	..	..	..	..	568,162	
Fines — <i>Country Roads Act No. 6229</i>	5,061	..	..	..	..	..	..	..	..	5,061	
General Receipts	855,372	..	..	..	..	..	..	..	..	855,372	
<i>State Loan Funds Act No. 6229</i>	..	..	300,000	..	..	..	..	..	..	300,000	
<i>Commonwealth Aid Roads Act 1969</i>	..	..	..	32,492,478	4,870,000	16,910,000	990,000	..	..	51,760,397	
Commonwealth Grant — Traffic and Road Safety Improvement	..	..	..	..	..	..	11,106	..	..	11,106	
	\$42,997,407	\$10,358,794	\$300,000	\$32,492,478	\$4,870,000	\$16,910,000	\$990,000	\$11,106	..	\$108,929,785	
<b>PAYMENTS</b>											
<b>Road Expenditure</b>											
<b>Main Roads—</b>											
Construction and Reconstruction	8,590,313	..	..	2,625,770	12,237	2,305,415	..	953	13,534,688	..	
Maintenance	3,253,535	3,354,661	..	..	..	..	..	..	6,608,196	20,142,884	
<b>State Highways—</b>											
Construction and Reconstruction	4,122,249	..	300,000	2,737,131	3,920,717	..	..	2,237	11,082,334	..	
Maintenance	929,564	6,659,706	..	..	..	..	..	..	7,589,270	18,671,604	
<b>Freeways—</b>											
Construction and Reconstruction	3,663,591	..	..	18,811,767	..	..	..	..	22,475,358	..	
Maintenance	369,342	344,427	..	..	..	..	..	..	713,769	23,189,127	
<b>Tourists' Roads—</b>											
Construction and Reconstruction	932,153	..	..	99,868	..	..	..	..	1,032,021	..	
Maintenance	827,898	..	..	..	..	..	..	..	827,898	1,859,919	
<b>Forest Roads—</b>											
Construction and Reconstruction	369,869	..	..	..	..	..	..	..	369,869	..	
Maintenance	539,998	..	..	..	..	..	..	..	539,998	909,867	
<b>Unclassified Roads—</b>											
Construction and Reconstruction	2,095,818	..	..	3,156,808	34,782	9,626,616	..	7,916	14,921,940	..	
Maintenance	849,755	..	..	..	..	3,331,079	..	..	4,180,834	..	
<b>Contribution to Melbourne and Metropolitan Tramways Board—</b>											
Tram Tracks Reconstruction	200,000	..	..	..	..	..	..	..	200,000	19,302,774	
<b>Murray River Bridges and Punts</b>											
Traffic Line Marking	176,683	..	..	..	..	..	..	..	..	176,683	
	652,328	..	..	..	..	..	..	..	..	652,328	
<b>Statutory Payments</b>											
Interest and Sinking Fund	2,618,683	..	..	..	..	..	..	..	..	..	
Research Grant— Melbourne University	4,000	..	..	..	..	..	..	..	..	..	
Traffic Authority Fund	354,278	..	..	..	..	..	..	..	..	..	
Tourist Fund	708,555	..	..	..	..	..	..	..	..	..	
Transport Regulation Fund	584,684	..	..	..	..	..	..	..	..	..	
	4,270,200	..	..	..	..	..	..	..	..	4,270,200	
<b>Planning and Research</b>	45,694	..	..	..	..	..	990,000	..	..	1,035,694	
<b>Capital Expenditure</b>											
Plant Replacement and Additions	1,115,562	..	..	..	..	..	..	..	..	..	
Buildings, Workshops, etc.	565,000	..	..	..	..	..	..	..	..	..	
	1,680,562	..	..	..	..	..	..	..	..	1,680,562	
<b>Management and Operating Expenditure</b>	8,596,245	..	..	5,061,134	902,264	1,646,890	..	..	..	16,206,533	
	\$42,165,797	\$10,358,794	\$300,000	\$32,492,478	\$4,870,000	\$16,910,000	\$990,000	\$11,106	..	\$108,098,175	
Balance as at 30th June, 1974	\$831,610	..	..	..	..	..	..	..	..	\$831,610	

R. G. COOPER,  
Chief Accountant,  
25th September, 1974.

#### AUDITOR-GENERAL'S CERTIFICATE

The accounts of the Country Roads Board for the year ended 30th June, 1974, have been audited. In my opinion the above Statement of Receipts and Payments fairly presents in summary form the transactions during that period.

B. HAMILTON,  
Auditor-General,  
8th October, 1974.

## APPENDIX 9

### COUNTRY ROADS BOARD

#### Loan Liability as at 30th June, 1974

	Main Roads, etc.	Developmental Roads	TOTAL
<b>Permanent Works</b>			
Main Roads	16,730,322.16		16,730,322.16
State Highways	18,004,304.20		18,004,304.20
Freeways	3,000,000.00		3,000,000.00
Tourists' Roads	227,316.44		227,316.44
Forest Roads	2,167.89		2,167.89
Developmental Roads		12,851,515.09	12,851,515.09
Discount and Expenses	738,883.47	582,856.40	1,321,739.87
<b>Total Amount Borrowed</b>	<b>\$38,702,994.16</b>	<b>\$13,434,371.49</b>	<b>\$52,137,365.65</b>
<b>Less Redemption of Loans</b>			
Redemption Funds	170,438.11	1,292,772.73	1,463,210.84
Main Roads Sinking Fund	571,376.76		571,376.76
Developmental Roads Sinking Fund		110,166.02	110,166.02
State Loans Repayment Fund	3,333,874.57		3,333,874.57
National Debt Sinking Fund	7,346,185.71	7,121,787.49	14,467,973.20
Consolidated Fund	13,547.03		13,547.03
	<b>\$11,435,422.18</b>	<b>\$8,524,726.24</b>	<b>\$19,960,148.42</b>
<b>Loan Liability at 30th June, 1974</b>	<b>\$27,267,571.98</b>	<b>\$4,909,645.25</b>	<b>\$32,177,217.23</b>



## APPENDIX 10

### Works Executed on Behalf of Commonwealth and State Government Authorities for the Year Ended 30th June, 1974

(Adjusted to Nearest Dollar)

Departments	Description of Works	Expenditure
<b>Commonwealth—</b>		
Department of Works	Access roads to various Commonwealth establishments	9,945
<b>Victoria—</b>		
Housing Commission	Roadworks in connection with Cardinia Creek Overpass at Riggall Street, Broadmeadows City	179,212
Melbourne and Metropolitan Board of Works	Reservoir, Tullamarine and Mulgrave Freeways	213,002
Premier's Department	Roadworks — Wonderland and Sundial Roads — Stawell Shire	600
Rural Finance and Settlement Commission	Roadworks in Commission land settlement projects throughout the State	12,575
State Electricity Commission	Road and bridge works in connection with extension of Morwell Open Cut, removal of tram tracks in Ballarat and Bendigo	814,552
State Rivers and Water Supply Commission	Road and bridge works in connection with Dartmouth Dam Project	94,257
State Treasury	Kings Bridge—Sundry expenditure less proceeds of rental of properties acquired in connection with construction of Kings Bridge	8,399 Cr.
" "	Grade Separation Projects, etc., charged to Level Crossings Fund and Victorian Railways Board	415,569
" "	Grade separated pedestrian crossings charged to State Treasury and Municipalities	164,835
" "	Improvements to various roads adjacent to State Forests to facilitate the extraction of timber and charged to the Municipalities Forest Roads Improvement Fund	46,971
" "	Construction of roads and bridges charged to the Roads (Special Projects) Fund	7,643,373
" "	Unemployment relief — roadworks	166,803
		8,429,152
		<u>\$9,753,295</u>



**CHIEF ENGINEER'S REPORT**

Country Roads Board  
Melbourne

THE CHAIRMAN,

I have the honour to submit the Chief Engineer's Report for 1973/74. The report deals with those activities within the Chief Engineer's Branch which are considered to be of general and special technical interest.

W. S. BRAKE,  
Chief Engineer





## 1. DESIGN

## BRIDGE COMPUTER PROGRAMS

The Board's IBM 1620 computer was used extensively throughout 1973/74 as an aid in the design of approximately 80 different bridges. Design use included the analysis of superstructures and substructures, geometry calculations, preparation of specifications and preparation of reinforcement schedules. No new programs were developed for the 1620 during the year, but all existing programs have been converted to accept metric input and give metric output. The Reference Listing of Standard Specifications for Bridge Works was revised and converted to metric units, and the revision has been in use since January 1974.

Use of the Bridge Sub-branch's Hewlett-Packard programable calculators has become a routine part of the design process, and their usage continues to increase. There are now four Hewlett-Packard 9810A calculators in the Bridge Sub-branch, of which two accept 500 step programs and two accept 2000 step programs. Many new programs have been developed in the past year for the 500 step calculators, including programs for the design and analysis of beams, and the analysis of columns, in both the cracked and uncracked condition. Larger programs to take advantage of the 2000 step calculators will be developed in the coming year. Most of the more recently developed Hewlett-Packard programs have been written to accept consistent units, i.e. the programs are applicable to either metric or imperial measurements, so that no metric conversion procedures have been necessary. All programs previously written using imperial units have now been converted to metric form.

## SNOWY RIVER BRIDGES AT ORBOST

Design is complete for an all weather crossing to carry the Princes Highway over the Snowy River and flood plains at Orbost. As design was commenced in imperial units, it was decided not to convert to metric in this case. The new crossing will include three major bridges with a total length of 3,900 ft, and a 4 mile realignment of the highway from Newmeralla in the west to a by-pass of Orbost in the east (Figure 1).

The history of bridges at this site has been eventful. The first bridge over the river, a timber structure with a central suspended span of about 150 ft, was constructed late in the nineteenth century. After the conclusion of the first World War, the Victorian Railways considered an extension of the railhead across the river into Orbost, and in 1922 a new timber and steel girder structure, a joint Country Roads Board-Victorian Railways venture, was built, and completed at a cost of £14,000 (the steel girders came from the Flinders Street viaduct reconstruction). The railway was not taken across the river, but the bridge was put to use to carry the highway across and it serves this purpose at present. The bridge has been severely battered by floods during its life. In 1934 two central spans were swept away and were subsequently replaced by a welded steel truss that is still in place. Extensive repairs to piling at the western end of the welded truss span became necessary in 1952 and the Orbost abutment was washed away in February 1971.

The highway approaches to the existing bridge are on poor alignments and several serious accidents have occurred at the Orbost end. In times of heavy floods the highway on both sides of the river has been cut by floodwater and during the 1971 floods, the highest ever recorded, the river was a mile wide at the crossing.

The new alignment provides a flood plain crossing of 6,640 ft, sited just downstream of the existing river bridge and the railway, at the narrowest section of the flood plain. Commencing at the high ground of the Newmeralla bank, the first bridge will be 1,960 ft long across a depression known locally as Ashby's Gulch. The second bridge will be 700 ft long across Watts Gulch and the third, 1,240 ft long, will span the Snowy River and a lagoon to high ground at the Orbost end. The lengths of the earth embankments between the bridges will be 1,040 ft and 1,700 ft, matching the lengths of embankment between the railway viaducts. The combined waterway to be provided by the three bridges is designed to cater for a flow of 300,000 cusecs, which is about 40,000 cusecs more than the recorded flow of the 1971 flood. The underside of the superstructure of the bridges will be 6 ft above the level of the 1971 flood to ensure clearance for the large trees which are washed down by severe floods.

The river bridge will have five 100 ft and two 90 ft spans over the permanent channel of the river and eight 70 ft spans across the lagoon. The two bridges across the gulches will have a total of thirty-eight 70 ft spans. The beams will have a new type of U-shaped prestressed concrete section and the cast *in situ* decks will provide continuity across the piers. The deck cross-sections and pier types are shown in Figures 2 and 3.

The beams are designed U-shape in section instead of I-shape, to reduce the risk of snagging by debris and to provide sufficient lateral stiffness to resist the impact forces of large trees brought down by flood waters. The U-beams are not as deep as the equivalent I-section, the span to depth ratios being between 23 and 27, compared with the more usual ratio of 21. The cross-sectional shapes selected allow beams to be cast in the same formwork for spans varying from 70 ft to 100 ft. The increased section area required for the longer spans is provided by raising the inner form (Figure 4).

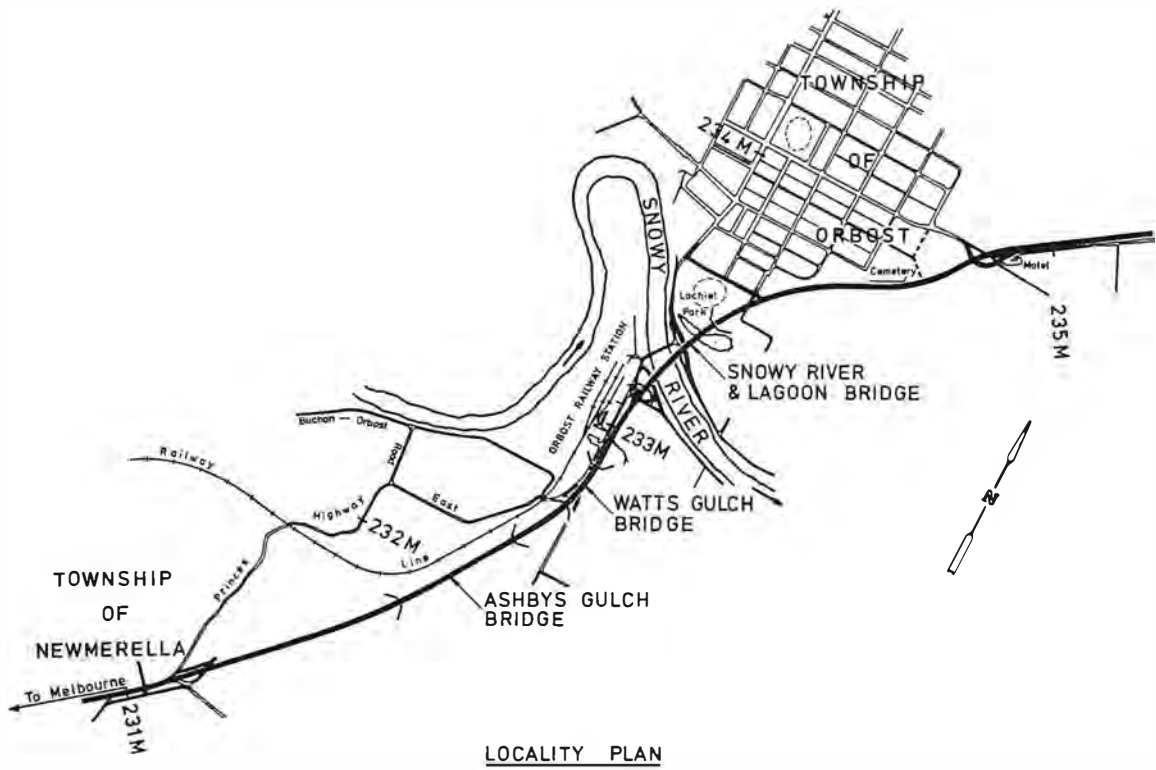

Figure 1—Princes Highway bridges at Orbost. Locality plan.

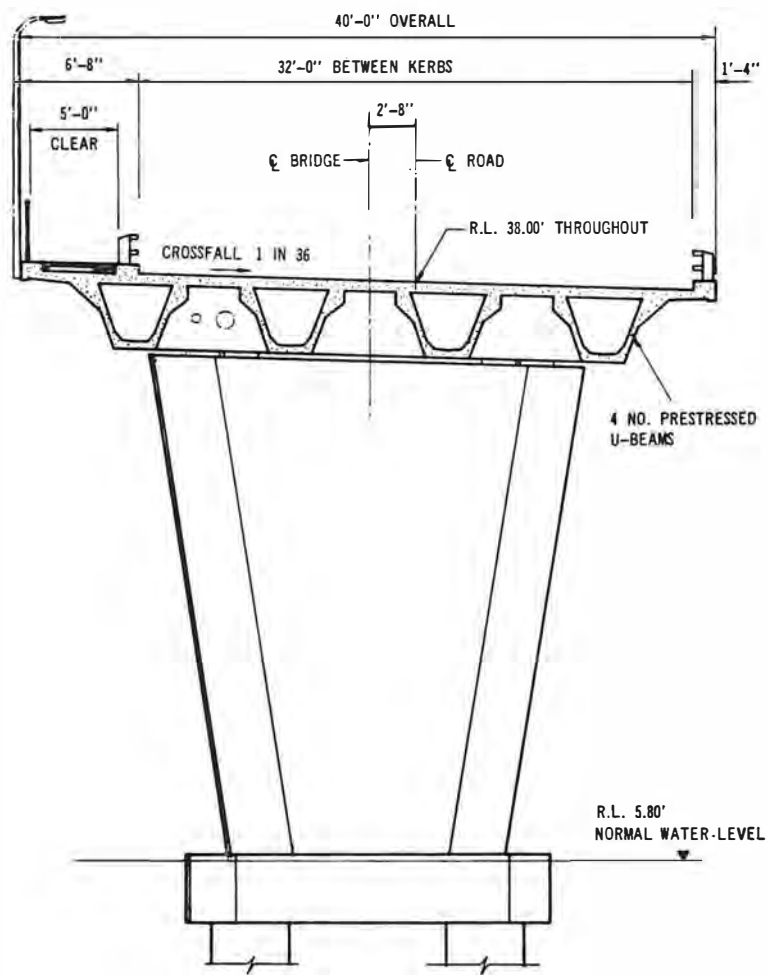

Figure 2—Princes Highway bridge over Snowy River, Orbost. Cross-sections of deck and pier types.



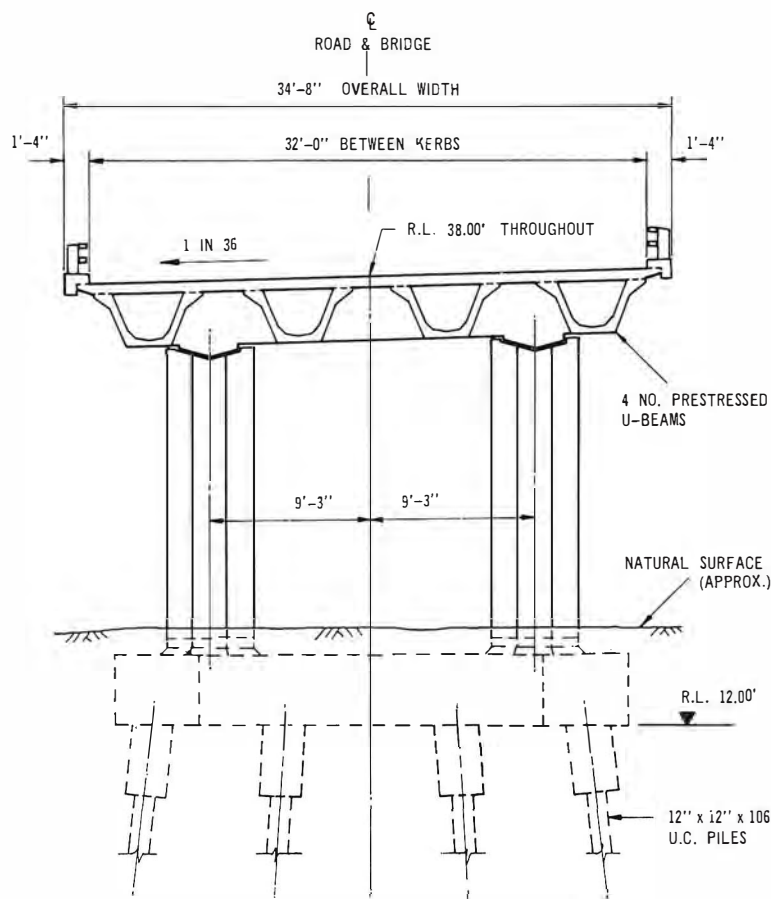

Figure 3—Princes Highway bridges over Ashby's Gulch and Watts Gulch, Orbost. Cross-sections of deck and pier types.

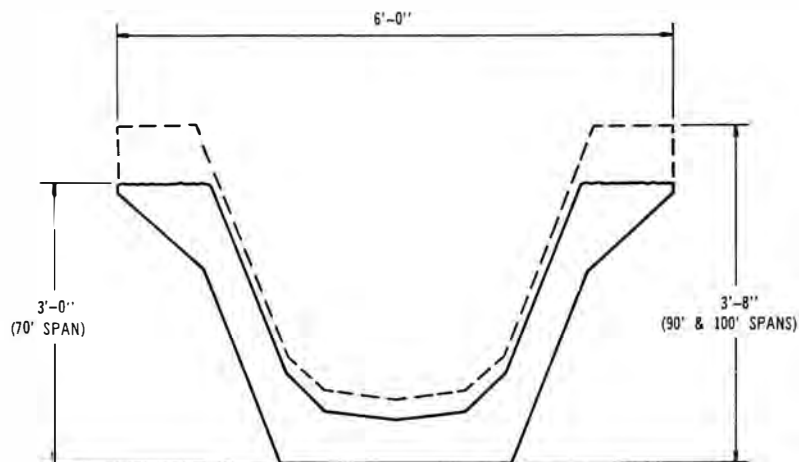

Figure 4—Princes Highway bridges at Orbost. Cross-section of U-beam.

Investigation bores revealed considerable depths of soft, compressible alluvial silts overlying hard siltstone at the river bridge and dense gravels at the Gulch bridge sites. Each pier of the river bridge will be supported on two 4 ft 6 in. diameter reinforced concrete cylinders which will extend into the siltstone. The maximum length of the cylinders will be 65 ft. The foundations of the Gulch bridges will be steel H-piles driven down to the dense gravels at an average depth of about 90 ft. These piles are designed to withstand down-drag forces which are expected to result from the process of driving the piles through the compressible silts. Some of the piles will be instrumented to monitor the down-drag forces and some will be coated with bitumen to assess the value of such a coating for the reduction of down-drag forces.

The road embankments between the bridges will be constructed and surcharged before the bridgeworks are due to commence to allow as long a time as possible for consolidation of the alluvial deposits across the flood plain.

## 2. CONSTRUCTION

### PRODUCTION OF PRECAST POST-TENSIONED REINFORCED CONCRETE BEAM SEGMENTS

Precast post-tensioned reinforced concrete I-beam segments for use on bridges on the Hume Freeway, Wallan-Broadford Section, are being manufactured at the Bendigo Division precasting yard. Production rates have been facilitated and high quality standards maintained through careful design and construction of the formwork, and attention to detail during production.

The two sets of formwork (Plate 1) are constructed in 50 ft lengths, initially for the simultaneous manufacture in each set of two 22 ft long segments for use on the overpass of the North Eastern Railway, and later for the manufacture of 40 ft segments for the Sunday Creek bridge. The forms are constructed from rolled steel sections, and plates with a minimum thickness of  $\frac{1}{4}$  in. Use of the heavy sections has been found to be warranted, as it is obvious that, with the employment of form vibrators, a poorer quality product would have resulted had lighter sections been used. During construction of the forms, welding was kept to a minimum, light rods were used, and the order of welding was carefully controlled in order to keep distortion to a minimum. The forms are constructed so that the end sections of beams containing the end block anchorage for post-tensioning can be cast in them (in order to cast centre sections, the end section is blocked off by the use of end boards placed inside the forms). Also, the forms are built to allow for either a NAASRA standard I-beam section with a 6 in. web thickness or a beam with an 8 in. web thickness and a corresponding 2 in. increase in the flange widths for longer spans.

Bolted connections are kept to a minimum on the formwork, and the extensive use of over-centre locking devices facilitates rapid setting up and stripping. The forms are made watertight by the use of inbuilt rubber sealing strips.

The following tolerances, which are well within the specifications, are being obtained and demonstrate the accuracy of the formwork construction:

- cross section  $\pm 1/16$  in.
- squareness of end  $\pm 1/16$  in.
- length  $\pm 1/8$  in.
- profile in any plane  $\pm 1/16$  in.

The segments are heavily reinforced with steel cut and bent to shape at the Syndal bending shop. Reinforcement tying is speeded by the use of jigs, which allow ligatures and main bars to be tied according to preset measurements. The reinforcement material, structural grade mild steel, is tied together by spot welding, which is quicker than wire tying, allows more precise location of bars and gives a cage which can be handled conveniently without the bars slipping out of place.

Accurate positioning of the prestressing ducts prior to casting is achieved by the use of measuring devices manufactured at the Bendigo yard, which are used at 3 ft intervals along the beam to accurately control both the vertical and the horizontal curvature of the ducts (Plate 2).



Plate 1—Setting up I-beam form.



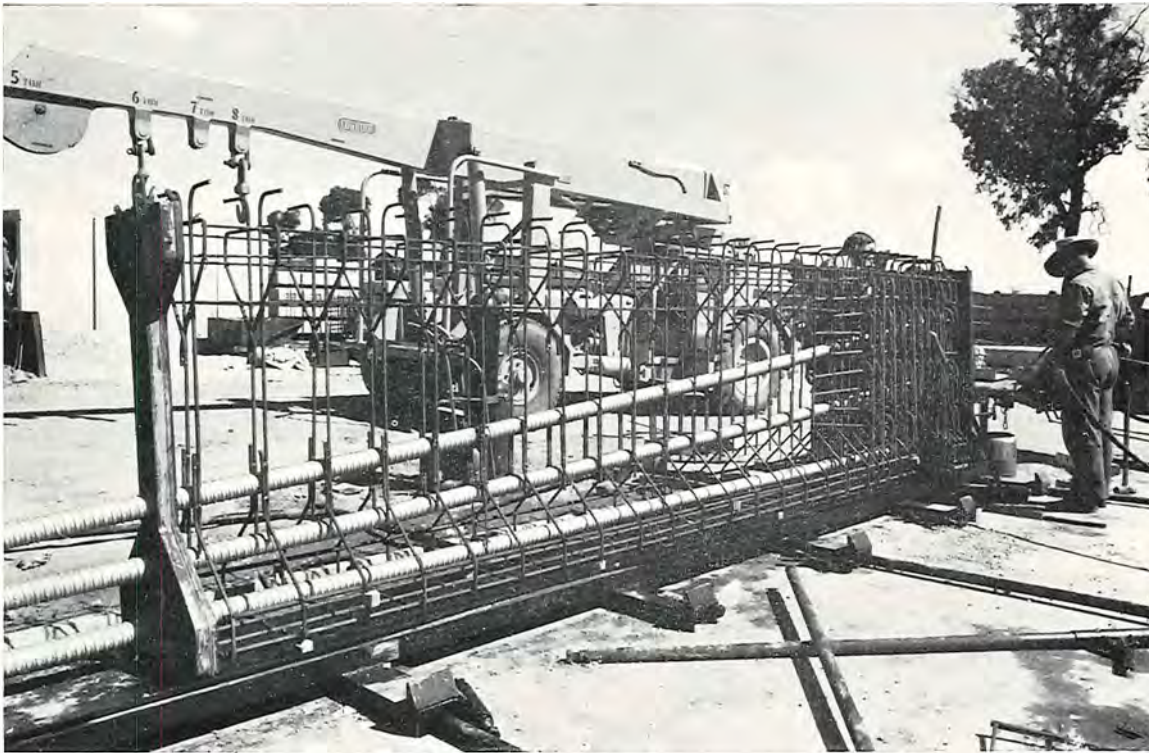

Plate 2—*I-beam reinforcement and prestressing hardware set up on base.*

A strength of 7,000 psi at 28 days is specified. Although this can be achieved with a 7 bag mix, a 9 bag mix is used to achieve high early strength and to eliminate “bleeding”. The mix consists of  $\frac{1}{2}$  in. maximum size aggregate with a slump of  $1\frac{1}{4}$  in. The segments are water cured and the side forms are stripped daily. Three bases are used, and as the casting rate is one segment per day, the segments are shifted off the casting floor three days after casting.

## MECHANICAL SUB-BRANCH

### DESIGN AND DEVELOPMENT

The following design, development or construction work either has been completed or is in progress:

(i) Linemarker positioning system

An optical system, based on ordinary mirrors, for positioning traffic linemarking machines has been developed. The system allows the positioning of a machine in the centre of a pavement without the need for white spots to be painted on the pavement. An experimental fitting on one linemarking unit is satisfactory and the system will now be tried on other units.

(ii) Airless paint-spray system for linemarking machines

Experimental equipment for the evaluation of an airless paint-spray system for linemarking machines is under construction. The system promises savings in the quantity of paint required to produce satisfactory road markings and may enable greater speeds of operation, compared with the conventional method of application. It was necessary to design and manufacture high pressure pumping components that are not available in Australia. As an adjunct to the above experiment, development is also proceeding on a new, air-pressure operated gun to dispense reflective glass beads at lower cost than at present.

(iii) Measurement of noise and vibration from traffic and construction equipment

Investigation has been completed into the development of a noise measuring system, using multiple microphones, initially for measurement of noise contours adjacent to existing freeways. The purpose of the system will be to provide the Board with a bank of data that will be used for the establishment of effective prediction methods for noise patterns near freeways in urban and future urban areas, so that noise reduction features may be incorporated during the design stage of proposed freeways. The system will also be able to measure traffic-caused vibration of neighbouring structures and noise emanating from construction equipment.

A mini-computer will control the system and provide all the necessary data in the minimum time with a minimum use of manpower.



## PLANT MAINTENANCE AND INSTALLATION

- (i) A chassis dynamometer to provide facilities for carrying out tests, under simulated field conditions, on both new and overhauled pneumatic tyred machines has been obtained. It will also be possible to utilize this unit in connection with exhaust gas analysis.
- (ii) A brake testing machine, which will enable testing of the braking systems of plant and vehicles under simulated field conditions, has also been obtained.

The above items of test machinery will both be installed soon within the workshop area, in such a manner as to minimize their possible noise and exhaust gas pollution effects.

- (iii) A diesel alternator set with a 300 kva continuous rating is being installed, to make the Bridge Sub-branch precast yard, steel fabrication shop and steel bending section at Syndal independent of the SECV supply during power emergencies.
- (iv) A hydraulically operated drill and penetrometer unit, designed by the Materials Research Division, has been manufactured in the Central Workshop and is mounted on a 6 x 6 International chassis.

## PLANNING SUB-BRANCH

### 1. ADVANCE PLANNING DIVISION

#### AUSTRALIAN ROADS SURVEY 1969/74

After the completion of the work by the Board outlined in the 1972/73 Report, the survey data was submitted to the Commonwealth Bureau of Roads in the format defined in the survey specification. The Bureau summarized the inventory and project information for the use of the Board and municipalities and also subsequently made the results of the evaluation process available. Relevant data covering the rural declared and unclassified road system and the declared outer suburban roads will be distributed to the regional Divisions in the early part of the 1974/75 year. This data includes the more important of the inventory information, project details for deficient structures and crossings, and the benefit/cost ratios of the projects. Since project costs were not individually generated but were based on an average unit-cost matrix, the project costs are not suitable for budgeting of individual projects. However, the costs and the benefit/cost ratios provide general indications as to the economic worth of projects.

Standard maps at a scale of 1 : 100,000 covering the whole of Victoria are being amended and will be distributed to the regional Divisions and municipalities during the 1974/75 financial year. These maps will be used for future road surveys and can be used as standard maps for administrative purposes.

“Strip maps” covering the rural and outer urban declared and proclaimed road network in Victoria have been distributed. These strip maps are computer print-outs showing the distances of the most important features along the roads (side roads, structures, municipal boundaries, mile posts, etc.). The distances on the strip maps are shown in both miles and kilometres.

Updating of the inventory information was commenced during 1973/74.

### 2. FREEWAY PLANNING DIVISION

#### SELECTION OF OPTIMUM ROUTES BY DYNAMIC PROGRAMMING

Development work was completed on OPTLOC (II) i.e. “Optimum Location of Road Alignment”. This is a dynamic approach to the selection of optimum routes, a computer system to be used as an aid in the location of rural highways. The principal function of the OPTLOC system is to select, from all possible alternatives within a given geographical band of interest, that route which minimizes the combined total of construction costs and projected user costs. Dynamic programming, by which OPTLOC selects minimum-cost routes, is a standard optimization technique applicable to certain types of multi-stage decision problems. The stages in the case of highways are evenly spaced cross-sections through the band of interest being investigated.

The system can be used in one of three ways: either to select a minimum-cost route in three dimensions, or to select an optimum vertical profile for a given horizontal alignment, or to evaluate a route that is completely specified geometrically. The system may be used to examine the effects of variations in values of items of input, such as unit cost rates, geometric standards and other constraints. The control areas specified by the system are of particular interest in this respect, in that they enable the planner to introduce the effects of matters of judgment or policy so as to use or to avoid any particular feature in the band of interest.

## 1. PLANS AND SURVEYS DIVISION

During 1973/74 the trend from the design of undivided rural roads towards the design of divided arterial roads and freeways continued. The developments set out below were connected with this trend.

“Task forces”, consisting of representatives of most Head Office Divisions together with construction management personnel, have been created to deal with the design of some major projects. Each such team is set up to resolve particular problems where the combined expertise of officers from the various Divisions is used to provide the answers required in the minimum of time.

The production of high quality plans has been facilitated by the introduction of varityping machines which assist in the standardization of lettering. Also, plastic drafting film has totally replaced drafting linen.

A 105 mm viewer-printer was installed in the Plan Filing Section to enable more convenient viewing of enlargements of plans and the quick production of prints from statfile negatives, thus obviating the need to employ the slower statfile camera technique.

For the first time, consultant landscape architects were engaged on two major freeway projects, to work in close conjunction with the design teams. The objective of the landscape studies was to enhance the scenic appeal of the freeways and a general review of the alignments and interchange layouts in terms of visual aesthetics, landmarks and vegetation was included accordingly. The consultants advised on tree plantation patterns, earthshaping design, noise reduction and the overall visual appeal of the two freeway projects.

In order to accelerate the surveys required on the Hume Freeway corridor, three consultant surveying firms were engaged for detailed feature surveys on sections which are to be designed on other than a photogrammetric base.

An orthoprojector was purchased for the production of base mapping orthophotography (i.e. true-to-scale photography) and attached to one of the Board's Wild A8 stereoplotters at the Department of Crown Lands and Survey. The orthophotographic system, combined with topographic plans, was used to produce contoured, true-to-scale photographs for preliminary location work in the Geelong and Ringwood areas. Later, this technique will be used for the planning and preliminary design work on major projects.

During 1973/74 the Board's first Schedule of Rates contract specification for a major freeway was prepared, in conjunction with the Mulgrave Freeway Project Engineer, for the Mulgrave A1 contract. Previous roadworks specifications had been based on Bulk Sum type contracts.

The Plans and Surveys Division was largely responsible for the metric conversion of the Road Design Manual, Freeway Design Manual, Engineering Survey Manual, Drafting Manual — Roadworks, Book of Standard Drawings, and Transition Curve Tables. The metric editions of these manuals will be required for the design of all new jobs and are basically intended to meet the road design needs of the Board and municipalities. The metric conversion of the Standard Road Specifications was also commenced during 1973/74 in conjunction with representatives of other Divisions, emphasis being placed on the conversion of the Sections relating to materials. Thirteen standard road specifications had been completed in metric units by 30th June, 1974.

## 2. RIGHT OF WAY DIVISION

By 30th June 1974, State highways and tourists' roads had been completely surveyed for metric conversion and the locations for kilometric markings had been set out. The metric lengths of State highways and tourists' roads are:

State highways — 7217 km

Tourists' roads — 793 km

A new distance measuring instrument (D.M.I.) was acquired for use in the metric conversion programme. This instrument is a precision electronic instrument designed for computing and displaying measurements produced by a moving vehicle. The system uses sensing targets which are attached to the vehicle's right front wheel. As the wheel rotates the targets move past a magnetic sensing head, creating electrical pulses which are transmitted to a computing device. The distance travelled is shown on a digital read-out screen. The data entry facility allows the operator to enter previously measured distance into the D.M.I. prior to the re-commencement of measuring. The advantages of the D.M.I. are its simple and silent operation, ease of changeover between vehicles, and accuracy of  $\pm 100$  mm per kilometre during operation under controlled conditions.

## 3. TRAFFIC ENGINEERING DIVISION

### *Traffic Surveys*

The number of large scale traffic surveys again increased during 1973/74. They included origin and destination surveys at Shepparton, Traralgon, Swan Hill and Mildura, involving roadside interviews combined with number-plate surveys to give comprehensive data on travel patterns through those cities.

The Rural Traffic Index for 1974 was calculated at 248.9, a slight decrease from the 1973 value of 250.1. The reduction is not considered to be significant, in view of the somewhat random nature of traffic statistics. Examination of the Index over the past five years indicates an upward trend, with an average annual increase of 5.3%.

### Linemarking

Under the operation of the State linemarking programme before 1973/74, all roads in the State were restriped at intervals of 6 to 9 months. Following the introduction during 1973/74 of a system for rating the quality of existing linemarking, it has been possible to reduce the frequency of restriping in some circumstances.

Just prior to commencement of a linemarking programme for a particular area, an inspection is made and the condition of linemarking within the area is recorded according to the following rating

Rating	Appearance of Line
1	No apparent wear. Adequately beaded.
2	Slight wear, i.e. points of aggregate just apparent through paint as seen when driving. Adequately beaded. Does not require restriping.
3	Dull appearance due to pavement showing through worn paint as seen when driving. Some loss of beads but night time visibility adequate. Requires restriping in the near future for daytime visibility under adverse conditions (fog or at dusk).
4	Well worn, requires restriping.

A road rated as 1 or 2 would not be programmed for restriping during the forthcoming linemarking operation in the area, but a road rated as 3 or 4 would be so programmed.

It is hoped to develop restriping programmes on a needs basis and it may be possible in the future to derive a relationship to establish the required frequency of restriping from consideration of the traffic volume, seal width and horizontal alignment of a road.

The new system allows linemarking units to spend more time on those urban roads which require better service and, on those roads which require less maintenance striping, it will result in a reduction in the paint build-up and the subsequent chipping and cracking of the paint.

## WORKS SUB-BRANCH

### 1. ROAD CONSTRUCTION AND MAINTENANCE

#### DIRECT LABOUR ROAD CONSTRUCTION COSTS

Tables 1 to 4 set out analyses of the costs of 72 construction and reconstruction jobs completed by the Board during 1973/74 at a total cost of \$6.7m, together with the corresponding analyses for the preceding four years. Because of annual variations in regional and job mix factors and the number of cost statements submitted for analysis, the unit costs indicate only the general level of unit costs of carrying out particular stages of construction work.

**TABLE 1—DISTRIBUTION OF EXPENDITURE**

	Labour	Materials	Plant	Stores	Total
	%	%	%	%	%
1969/70	31.0	25.7	35.1	8.2	100.0
1970/71	34.3	20.7	33.9	11.1	100.0
1971/72	34.3	23.0	31.5	11.2	100.0
1972/73	33.9	27.5	28.0	10.6	100.0
1973/74	37.8	22.2	31.1	8.9	100.0
Five-year average, 1969/70 to 1973/74	34.0	24.1	31.9	10.0	100.0

**TABLE 2—WORKS OVERHEAD EXPENDITURE**

(Percentage of productive costs)

	Construction Overhead Expenses	Camp Expenses
	%	%
1969/70	13.2	10.0
1970/71	14.9	11.0
1971/72	15.6	9.8
1972/73	15.6	8.3
1973/74	17.2	9.4
Five-year average, 1969/70 to 1973/74	15.2	9.7



**TABLE 3—FORMATION COSTS**  
(Including distributed overhead expenditure)

	Rock		Earth Unclassified		Total	
	Quantity	Unit Cost	Quantity	Unit Cost	Quantity	Unit Cost
	cu yd	\$	cu yd	\$	cu yd	\$
1969/70	279,312	1.70	1,922,031	1.10	2,201,343	1.17
1970/71	45,833	1.46	1,569,324	1.17	1,615,157	1.18
1971/72	Nil	Nil	1,725,660	1.22	1,725,660	1.22
1972/73	84,037	2.11	1,390,696	1.19	1,474,733	1.24
1973/74	23,990	3.91	1,190,564	1.44	1,214,554	1.49
Five-year average, 1969/70 to 1973/74	86,634	1.88	1,559,655	1.21	1,646,289	1.24

**TABLE 4—PAVEMENT COSTS**  
(Consolidated in place, including distributed overheads)

	Fine Crushed Rock		Coarse Crushed Rock		Gravel, etc.		Total	
	Quantity	Unit Cost	Quantity	Unit Cost	Quantity	Unit Cost	Quantity	Unit Cost
	cu yd loose	\$	cu yd loose	\$	cu yd loose	\$	cu yd loose	\$
1969/70	112,174	4.03	54,899	3.59	1,291,970	2.32	1,459,043	2.50
1970/71	95,123	5.02	77,508	4.77	770,050	2.30	942,681	2.78
1971/72	183,036	5.84	63,925	5.90	1,234,323	2.57	1,481,284	3.12
1972/73	140,375	6.78	77,803	5.92	675,935	2.43	894,113	3.42
1973/74	94,513	6.11	48,295	6.18	784,870	2.87	927,678	3.38
Five-year average, 1969/70 to 1973/74	125,044	5.66	64,486	5.29	951,430	2.49	1,140,960	3.00

Table 5 sets out the movement in indices of prices affecting the Board's operations, as at 30th June of the years 1967 to 1974 inclusive (base = 100, 30th June 1967). The indices are based on actual prices ruling at the close of each period, and no attempt has been made to give weight to the duration for which price changes operated throughout the year.

**TABLE 5—INDICES OF PRICES AFFECTING THE BOARD'S OPERATIONS**  
(Base 30/6/67 = 100)

	30/6/67	30/6/68	30/6/69	30/6/70	30/6/71	30/6/72	30/6/73	30/6/74
Maintenance (all groups)								
Urban	100.0	103.4	113.7	120.1	134.1	146.8	166.4	210.5
Rural	100.0	103.3	113.0	120.2	133.6	146.3	166.5	210.1
Construction (all groups)								
Urban	100.0	106.3	114.6	118.6	129.1	137.7	152.0	183.2
Rural	100.0	103.9	111.9	117.9	128.7	139.0	157.8	196.0
Land Acquisition								
Urban	100.0	101.2	117.0	119.5	*125.5	*144.3	*160.0	*160.0
Rural	100.0	106.9	110.6	114.4	*118.8	*126.8	*137.0	*166.3
Board's direct works								
Urban	100.0	105.2	114.9	119.9	128.8	139.5	154.4	181.2
Rural	100.0	103.8	112.1	118.4	129.7	140.6	159.6	198.7
Composite urban (41%) and rural (59%)	100.0	104.4	113.3	118.6	129.3	140.1	157.4	191.5
Composite direct works and salaries	100.0	105.0	112.0	118.7	131.0	141.8	159.4	196.0
Annual % increase	—	5.0	6.7	6.0	10.4	8.2	12.4	23.0

\* Estimated.

## 2. MATERIALS RESEARCH DIVISION

### EXPERIMENTAL SEAL USING A SYNTHETIC AGGREGATE

A short test section of seal using the experimental synthetic aggregate "calcined pyrophyllite" was included in a section of seal applied by the Board to North Road, Ormond, in the City of Moorabbin as part of a regular maintenance reseal programme, in April 1974. Calcined pyrophyllite has been developed jointly by CSIRO and Vickers Ruwolt Research Pty. Ltd. Vickers Ruwolt arranged for the supply, firing, crushing and delivery of the calcined pyrophyllite at no cost to the Board.

Calcined pyrophyllite is a white aggregate with a high luminance factor. It is likely to be a relatively expensive material and as such is intended for use only in areas where pedestrians are common or delineation is required for traffic.

With the exception of three test sub-sections the maintenance reseal used older basalt from Pioneer Concrete (Vic.) Pty. Ltd., Narre Warren. The test sub-sections adjoined a 10-year-old, size 10, asphalt surface and Plate 3 shows an aerial view of the work. The three sub-sections, each 60 m long and 8 m wide, were placed in the westbound carriageway of North Road between Tyrone Street and Tucker Road, using the following aggregates:

- (i) calcined pyrophyllite exclusively (Plate 4),
- (ii) newer basalt from Albion Reid Pty. Ltd., Niddrie and calcined pyrophyllite, on a 2 : 1 basis (Plate 5),
- (iii) scoria from F. Westcott and Sons, Mt. Fraser and calcined pyrophyllite, on a 2 : 1 basis (Plate 6).

All aggregates used were 10 mm one-size and were spread at the rate of approximately 1 m<sup>3</sup> per 109 m<sup>2</sup>. The bitumen binder included rubber.



Plate 3—Experimental seal using calcined pyrophyllite synthetic aggregate. Aerial view of test sections on the west-bound carriageway of North Road, Ormond. From bottom to top the sections are (a) older basalt seal, (b) newer basalt/calcined pyrophyllite (2:1 ratio) seal, (c) calcined pyrophyllite seal, (d) scoria/calcined pyrophyllite (2:1 ratio) seal, (e) old asphalt surfacing.

Photograph by courtesy of Division of Building Research, CSIRO.



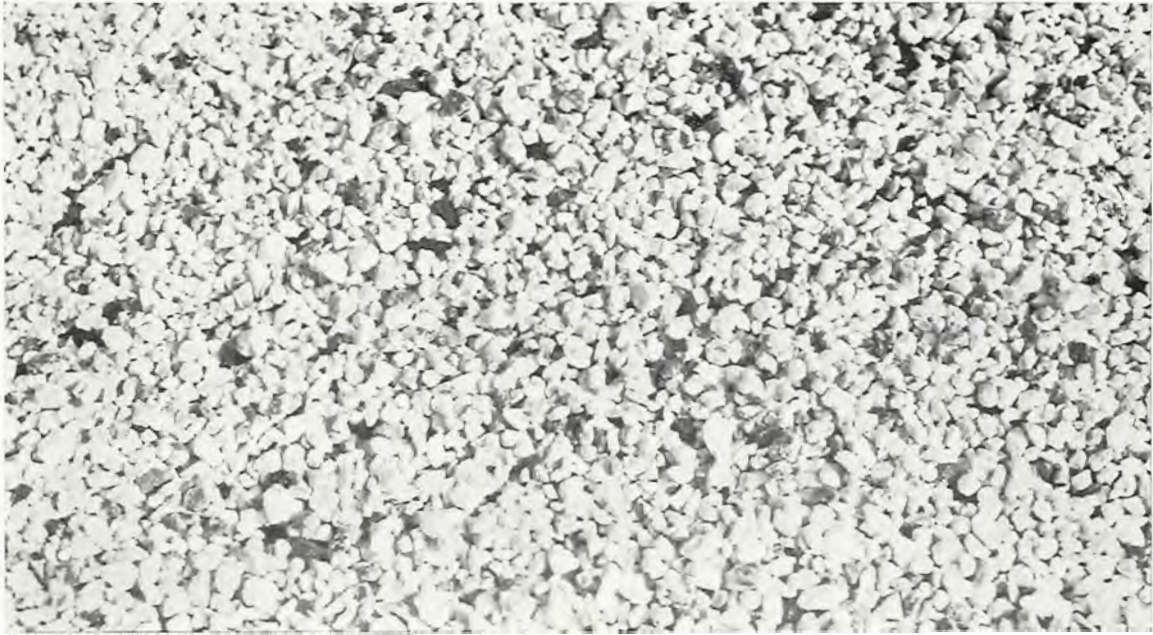

*Plate 4—Close up view of calcined pyrophyllite surface seal.*

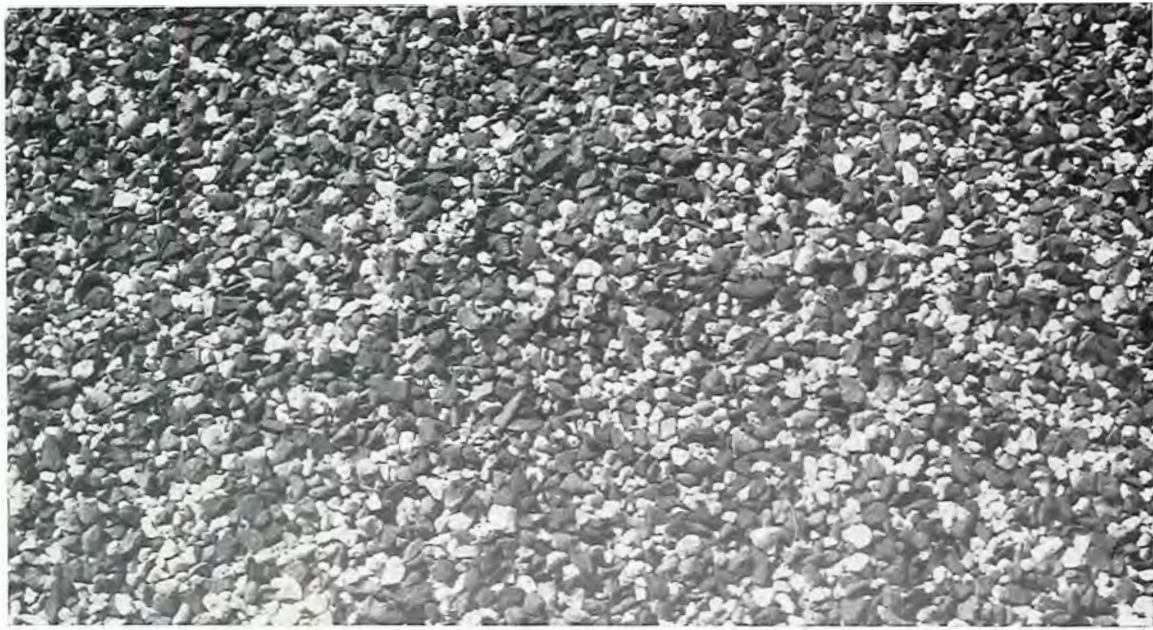

*Plate 5—Close up view of newer basalt/calcined pyrophyllite mix surface seal.*



*Plate 6—Close up view of scoria/calcined pyrophyllite mix surface seal.*



The sideways force coefficients (SFC) as determined by use of the SCRIM machine (Figure 5) indicate that all the experimental sections initially have improved skid resistance properties:

10 year old, size 10 asphalt surface	54
Older basalt	63
Newer basalt/calced pyrophyllite	77
Calced pyrophyllite	81
Scoria/calced pyrophyllite	84

Polished stone values (PSV) for the aggregates are:

Older basalt	41
Calced pyrophyllite	45
Newer basalt/calced pyrophyllite in 2 : 1 ratio	46
Scoria/calced pyrophyllite in 2 : 1 ratio	50

Laboratory luminance factor measurements were taken for the aggregates used and luminance measurements were taken at night for the laid material under lighting from the existing low pressure sodium vapour overhead lanterns. The results were as follows:

Materials	Luminance factor on aggregate	Luminance of laid material in the field
Older basalt	0.1	0.6
Calced pyrophyllite	0.6	1.4
Newer basalt/calced pyrophyllite in 2 : 1 ratio	0.2	0.9
Scoria/calced pyrophyllite in 2 : 1 ratio	0.2	0.9

The section will be inspected and tested regularly in the future to assess the performance of the aggregates in regard to such factors as breakdown, skid resistance and luminance.

CSIRO is working on the production of other synthetic aggregates with similar luminance and hardness properties and in a variety of shapes, but with increased skid resistance. The Board is co-operating in the testing of these aggregates.

#### DEFLECTION TESTING OF FULL DEPTH AND DEEP STRENGTH ASPHALT PAVEMENTS

Deflection testing on recently constructed full depth and deep strength asphalt pavements was carried out to measure the working deflections of these pavements. Table 6 summarizes the results.

The full depth asphalt pavement and the deep strength asphalt pavements with the cement stabilized crushed rock subbase are indicated to be strong pavements. The two pavements which have the highest deflections both have underneath the asphalt an unbound granular fine crushed rock layer which may allow moisture to enter the pavement, wetting the subgrade and leading to a loss of strength.

The indications from the test results are that with full depth and deep strength pavements it is possible to obtain average deflections lower than  $50 \times 10^{-2}$  mm, irrespective of subgrade and traffic conditions. In comparison, sound conventional flexible pavements usually have deflections in the  $50$  to  $80 \times 10^{-2}$  mm range and can tolerate these deflections without serious failure, during their design lives. A recent paper by Millard and Lister, which is reprinted in C.R.B. Engineering Note No. 100, presents relationships based on long-term testing in the English environment, between the life of a pavement and its deflection measured early in its life. For lives exceeding  $10^6$  standard axles the relations are of the form—

$$\text{Life} \propto \frac{1}{(\text{Deflection})^3}$$

From Millard & Lister, a deflection of  $36 \times 10^{-2}$  mm would allow the passage of  $10 \times 10^6$  standard equivalent 8165 kg (18,000 lb) axle loads. This would equal a service life of 20 years on a road such as Canterbury Road in the City of Box Hill. In essence, the lower the deflection the longer the service life that can be expected from a pavement.

#### AN EVALUATION OF THE PERFORMANCE OF SANDSTONE AND LIMESTONE PAVEMENT BASES IN HORSHAM DIVISION

A project to evaluate the performance of marginal materials as pavement bases is being conducted by the Materials Research Division. Recently a study of sandstone and limestone bases in service in the Wimmera and Mallee regions of the State was completed with the co-operation of Horsham Division. Test sites were selected at various locations on State highways and main roads. These sites were rated on a visual basis as either good, fair or bad and an attempt was made to correlate the results of field tests with these categories. Strength tests, density and moisture content determinations and deflection tests were performed in the field. Sufficient material was sampled to enable plasticity tests, particle size analyses, compaction tests, C B R tests and compressive modulus tests to be performed in the laboratory.

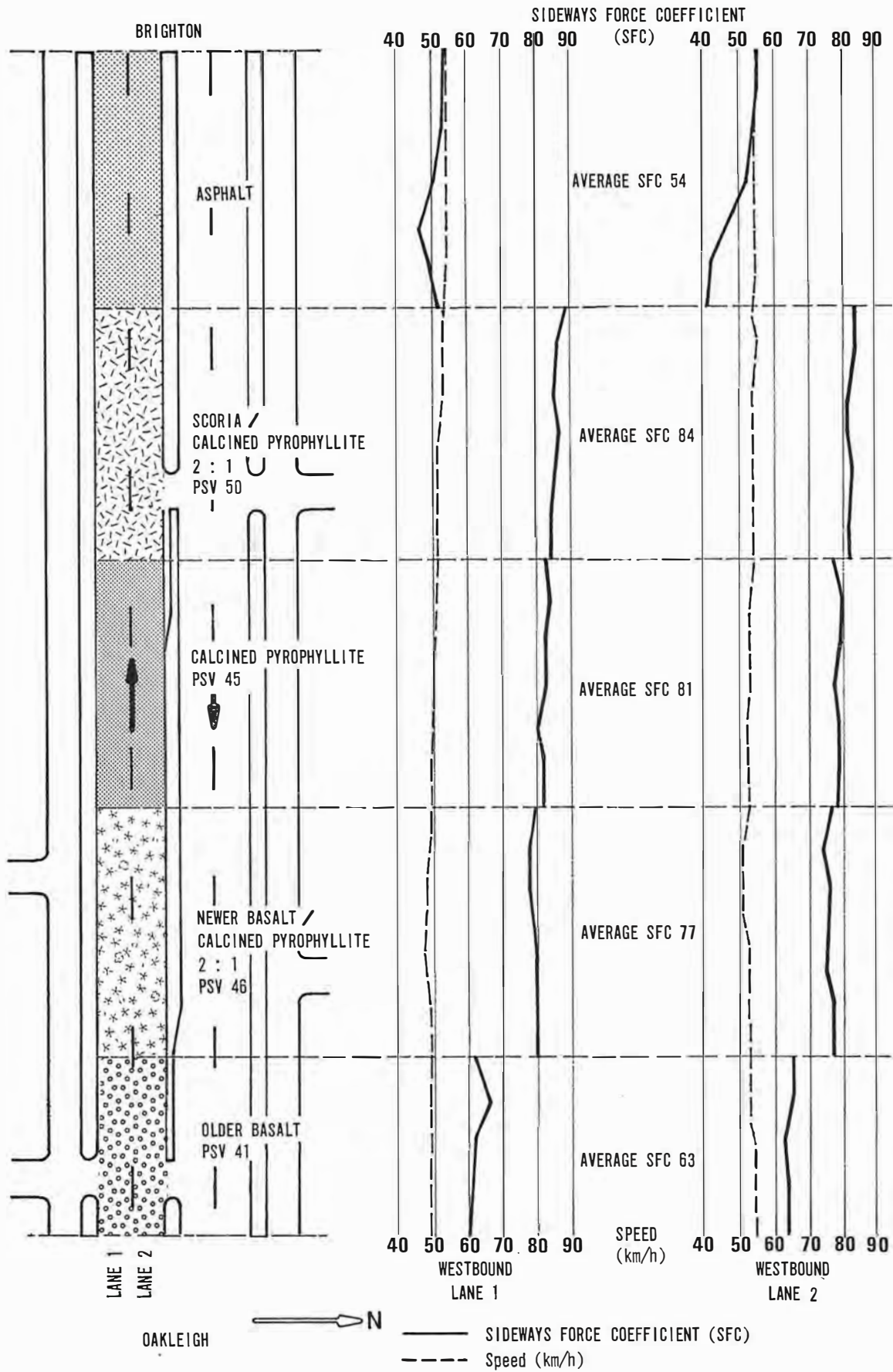

Figure 5—Skid resistance measurements from the use of SCRIM on experimental seal treatment, North Road, City of Moorabbin.

**TABLE 6—DEFLECTION TESTING RESULTS FOR FULL DEPTH AND DEEP STRENGTH ASPHALT PAVEMENTS**

Municipality	Road	From	To	Traffic Group (Commercial Vehicles)	Subgrade	Pavement		Average Deflection (x 10 <sup>-2</sup> mm)	Standard Deviation	Highest Deflection (x 10 <sup>-2</sup> mm)	Assessment
						Type	Make-up				
Coburg	Bell Street	Linsey Street	Sussex Street	1500-4500	Weak (CBR 3)	D S	250mm asphalt 100mm FCR 150mm cement stab. CR	30 *(12)	8 *(3)	56 *(22)	Strong and consistent
Heidelberg	Upper Heidelberg Road	Abbotsford Grove	Studley Road	1500-4500	Fair (CBR 5)	F D	250mm asphalt	43 (17)	18 (7)	127 (50)	Fair to strong
Box Hill	Canterbury Road	Benwerrin Road	Godfrey Court	1500-4500	Fair (CBR 5)	D S	200mm asphalt 125mm cement stab. CR	30 (12)	13 (5)	97 (38)	Strong and consistent
Northcote	Separation Street	Station Street	Sparks Avenue	450-1500	Weak (CBR 3)	D S	280mm asphalt 50mm cement stab. CR	48 (19)	18 (7)	102 (40)	Strong
Northcote	Wingrove Street	Street	Grange Road	450-1500	Weak (CBR 3)	D	50 mm FCR	76 (30)	25 (10)	152 (60)	Fair Arthur
Oakleigh	Atherton Road	Drummond Street	Atkinson Street	450-1500	Good (CBR 10)	D	75 mm FCR	51 (20)	8 (3)	71 (28)	Strong and consistent
Preston	Plenty Road	Dorrington Avenue	Tyler Street	450-1500	Good (CBR 10)	D S	200mm asphalt 125mm FCR	74 (29)	28 (11)	168 (66)	Fair

F D = Full depth asphalt pavement

D S = Deep strength asphalt pavement

\* Deflections in brackets = in. x 10<sup>-3</sup>

Field C B R tests were used at some sites, and plate bearing tests at others, to evaluate the *in situ* strength. The C B R test, in spite of some limitations to its use on larger sized material, appeared to be the more useful.

It was found that in service the sandstones had an average moisture ratio (field moisture content/optimum moisture content) of 0.95 and an average density ratio (field dry density/maximum dry density) of 0.92. The limestones averaged 0.80 for the moisture ratio and 0.92 for the density ratio.

The subgrades were usually drier than the bases even in areas of poor general drainage. In the case of the more sandy or gravelly materials this led to fairly high strengths: in three cases the subgrade was stronger than the base.

Plasticity properties and gradings varied widely. An increasing fineness from pit gradings to *in situ* gradings was evident for some sandstones. The tests confirmed that in drier areas, of low-traffic intensity, relatively high plasticity index and non-conformity with rigid grading limits were not factors limiting the satisfactory performance of base materials. In these areas, good construction methods and adequate maintenance appeared to make the difference between good and poor performance. There was evidence that a few materials are at the limit of their usefulness under present conditions. Large increases in traffic intensity or load may necessitate replacement of the base or upgrading by some form of stabilization.

#### OPEN-GRADED ASPHALT

Following some problems with skidding on existing road surfaces, and the successful use overseas of an open-graded asphalt (sometimes called "popcorn" mix) as a skid resistant wearing course for road pavements, the Board has developed a similar mixture, designed to have a very open grading and to contain a large percentage of inter-connected air-voids.

When laid, the open-graded asphalt provides a rough, open surface texture which allows water drainage not only at the surface but also through the asphalt. Improved tyre traction is thus afforded to vehicles traversing the open-graded asphalt during wet weather, and spray from tyres is minimized. Plate 7 shows open-graded asphalt and, for comparison, Plate 8 shows dense-graded asphalt.

Another advantage of the open-graded asphalt is that the open texture diffuses rather than reflects light from roadside sources and on-coming headlights, and thus minimizes the glare usually associated with wet night driving on asphalt surfaces. Also, the open-graded asphalt produces less tyre noise than does a dense-graded asphalt.

Open-graded asphalt, because of its rough surface texture and the rapid removal of water from its surface, produces high skid resistance values. Selection of an aggregate with a high polished stone value will ensure that a high level of skid resistance is maintained throughout the life of the road surfacing.



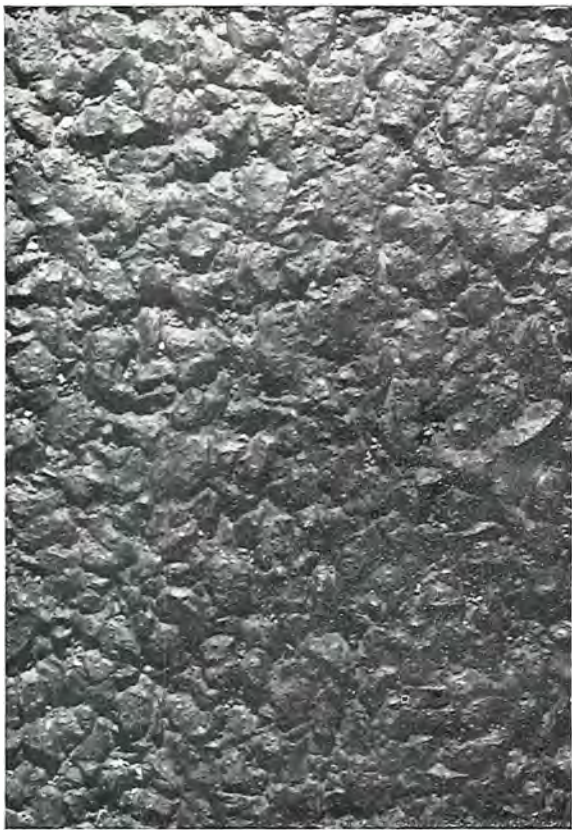

Plate 7—Size 10 open graded asphalt.

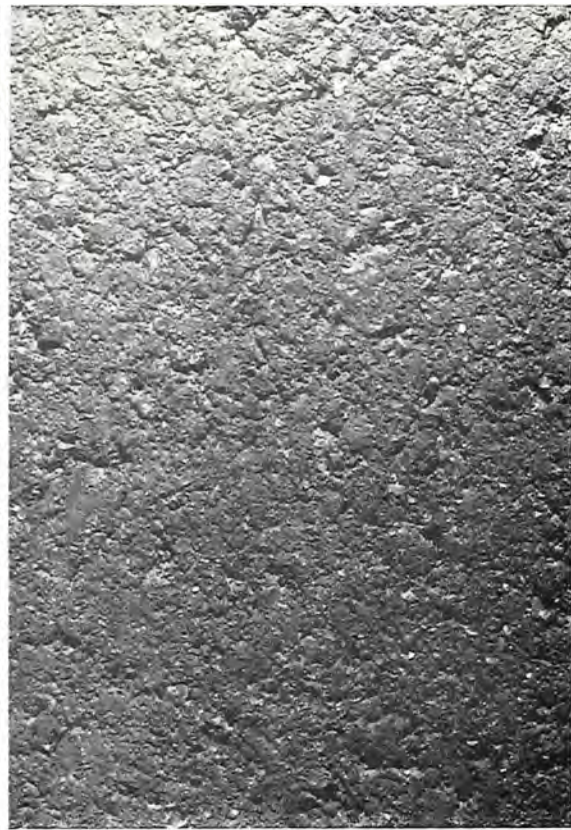

Plate 8—Size 10 dense graded asphalt.

The two following tables show grading envelopes and typical properties for size 10 open-graded and size 10 dense-graded asphalt:

Grading	Percentage Passing A.S. Sieves (by Mass)										Bitumen Content %
	13.20	9.50	6.70	4.75	2.36	1.18	0.600	0.300	0.15	0.075	
Size 10 open-graded asphalt	100	90-100	45-65	30-50	10-25	5-20	0-15	0-10	0-7	0-4	5.0-7.0
Size 10 dense-graded asphalt	100	90-100		58-70	40-53	27-44	17-35	11-24	7-16	4-7	5.0-7.25

Typical properties	Open Graded	Dense Graded
	Marshall stability (kN)	3350
Marshall flow (mm)	2.3	2.3
Air voids (%)	18	6
Voids in mineral aggregate (%)	29	17
Bulk relative density	2.09	2.36
Bitumen film thickness (microns)	17.5	9.0

#### CONCRETE SHRINKAGE INVESTIGATION

As a result of shrinkage cracking in the construction of concrete box girder bridges an investigation was initiated. For reasons of structural strength, box girders are normally constructed with concrete having a cement content of 445 kg/m<sup>3</sup> (8 bags/cu yd) and it was desired to know whether any practical reduction in shrinkage could be achieved by reducing the cement content to approximately 390 kg/m<sup>3</sup> (7 bags/cu yd). This change could only have been accepted if the 28 day cylinder strength of the mix was maintained at 41MPa (6000 psi), and to this end the possible use of concrete admixtures was also investigated.

In organizing the investigation programme it was decided:

- (a) to extend the work to cover the full range of cement contents normally used in structural concrete, and
- (b) that laboratory specimens, and also field sections placed under normal construction conditions, would be used. It was thus hoped to gauge the relationship between the laboratory and field behaviour of concrete.

The basic work of laboratory investigation involved the measurement of standard shrinkage prisms (76 x 76 x 286 mm or 3 x 3 x 11¼ in.) having cement contents of 335, 390 and 445 kg/m<sup>3</sup> (6, 7 and 8 bags/cu yd respectively). These had various water/cement ratios and were

cured under differing conditions. The specimen length one day after casting was adopted as a datum for all future dimensional changes. The average drying shrinkage results to 12 months are presented in Table 7.

**TABLE 7—DRYING SHRINKAGE AT 12 MONTHS OF PLAIN CONCRETE  
(335, 390, 445 kg/m<sup>3</sup>) STANDARD SHRINKAGE PRISMS**

Cement content (kg/m <sup>3</sup> )	335		390		445	
Water/cement ratio	0.56	0.51	0.51	0.46	0.46	0.41
Slump (mm)	150	38	150+	75	200	50
Drying shrinkage—microstrain (10 <sup>-6</sup> ) for specimens air cured from day no. 1	530	505	500	485	480	465
Drying shrinkage—microstrain (10 <sup>-6</sup> ), for specimens moist cured until day no. 7, and air cured thereafter	495	450	430	475	455	415

As part of the laboratory investigations, the shrinkage characteristics of some higher strength concretes that were being developed for a particular project, and also of some admixture concretes, were studied. It is interesting to note from the average results shown in Table 8 that the two mixes containing set retarder additives exhibited significantly higher drying shrinkages than either of the two plain concretes.

**TABLE 8—DRYING SHRINKAGE OF PLAIN AND ADMIXTURE CONCRETE (445, 560,  
585, 590 kg/m<sup>3</sup>) STANDARD SHRINKAGE PRISMS**

Slump (mm)	W/C Ratio	Cement Content (kg/m <sup>3</sup> )	Drying Shrinkage— Microstrain (10 <sup>-6</sup> )		Concrete Type
			91 days	182 days	
18	0.32	590 (10.6 bags)	385	440	Plain
45	0.32	585 (10.5 bags)	660	640	Set retarder added
45	0.37	560 (10 bags)	435	505	Set retarder added
50	0.41	445 (8 bags)	305	415	Plain

In the field investigation, instruments for recording strain changes and temperatures were placed in three typical components of bridge structures at the time of construction, in order to evaluate the shrinkage behaviour of a mass of structural concrete. The reading one day after casting the concrete was adopted as the datum for all strain measurements. The results are set out in Table 9.

**TABLE 9—DRYING SHRINKAGE OF CONCRETE IN STRUCTURES**

Site No.	1	2	3
Cement content of site mix (kg/m <sup>3</sup> )	445	335	335
Section details	600 mm deep flat slab	600 mm thick fender-wall	1150 x 760 mm crosshead
Field measurements			
(a) Maximum recorded internal concrete strain (microstrain)	119 expansion at 14 days	111 expansion at 14 days	128 expansion at 14 days
(b) Internal strain recorded at 28 days (micro- strain)	73 expansion	97 expansion	117 expansion
(c) Average surface strain recorded at 28 days (microstrain)	280 contraction	Not recorded	210 contraction
(d) Maximum recorded internal temperature	55°C at day 1	43°C at day 1	53°C at day 1
Laboratory measurements			
Shrinkage of specimens made from site mix			
(a) at 28 days (microstrain)	210	230	375
(b) at 182 days (microstrain)	470	475	630

Comments on and conclusions drawn from the investigations are:

- (a) that the laboratory work and, it appears, the field work indicate that there is no practical difference in the drying shrinkage behaviour of plain concrete mixes having cement contents of 390 and 445 kg/m<sup>3</sup> (and having a given slump, and which have been cured under similar conditions),



- (b) that strain measurements from the site concrete masses would appear to indicate that in the first two weeks after casting, a continuing expansion of the interior of the mass is superimposed on whatever thermal movements occur in this period (the strain measuring instruments used were temperature compensating). This phenomenon is considered to be mainly illusory and to be caused by concrete creep, for which the strain instruments cannot compensate; and
- (c) the field results indicate that in the early months after a concrete mass has been cast, many factors combine to produce a complex internal strain (and stress) condition.

#### MENARD PRESSUREMETER

The Board has purchased a Menard Pressuremeter for use in routine foundation investigations. The instrument measures the shear strength of soil and rock *in situ*, thus avoiding the difficulties both of bringing an undisturbed sample to the surface and the subsequent laboratory testing.

The pressuremeter consists of two main components:

- the probe (Plate 9), a cylindrical metal body with either a rubber membrane or a metal sheath fitted over it and designed to act as three independent cells. These cells are filled with water under controlled pressure from the volumeter.
- the volumeter, a fibre-glass container housing all the various regulators, pressure gauges, valves, etc.

The volumeter is connected to the probe by a flexible plastic conduit containing three tubes, each of which is connected to one cell of the probe (Plate 10).

In the field the probe is lowered into a previously drilled borehole to a predetermined depth. The cells of the probe are then steadily inflated, pushing the cylindrical surface of the cell outward against the wall of the borehole. By measuring the relation between the applied pressure and the increase in cell volume, parameters can be derived describing the load-settlement behaviour of the soil.

Together with current testing and sampling methods, the pressuremeter will be an aid in the estimation of bearing capacity and settlements for all types of shallow and deep foundations.

#### DATA BANK OF LABORATORY TEST RESULTS

Records of all reports concerned with investigations, research projects and tests on materials have been made on computer cards since January 1968 for Materials Research Division, and since January 1969 for regional Divisional laboratories. These computer cards provide a data bank which in some cases will indicate only the report number and type, and in other cases will include details of the test results. Computer listings are produced giving all report numbers, under the following headings:

- job number,
- materials supplier,
- type of testing, investigation or research.

The establishment of the data bank required:

- (i) the design of new report sheets, using a partly standard format, for each of the 32 different report sheets currently in use. To allow the coded information to be punched into computer cards and to produce also a report that can be read in the usual way, it has been necessary to produce two forms of each report sheet, viz., a draft which sets out encoded information in predetermined order and forms the instruction to the Computer Section, and a typed version for general distribution.
- (ii) the design of various codes, mainly numerical, to complement the well established job number system. These codes are amended and extended as required.
- (iii) a grid reference system, which was commenced in 1973. This uses the Military Survey Map series 1 : 250,000 and enables material sources anywhere in Victoria to be designated to an accuracy of approximately 1 km.

The advantages and uses of the data bank are that:

- (i) using any of the three listing print-outs, any report may be found. All reports are filed in simple numerical order, thus reducing the use of manual card indexing systems and/or other filing systems.
- (ii) for any construction job in Victoria, a print-out of most test results may readily be obtained. These results may be grouped according to whatever category is desired, e.g. material type, compaction density tests, etc. Sub-grouping may be made according to pavement course, the type of material, the source of the material and such like. Where the number of test results is sufficient, statistical values of mean, upper and lower limits and standard deviation can be supplied.
- (iii) a print-out of all test results on materials from any listed source may be obtained.





*Plate 9—Menard Pressuremeter. Probes with spare metal sheaths and rubber membrane. From left to right, small probe, metal sheath, rubber membrane, large probe, metal sheath. The metal sheaths are used for rock testing and the rubber membranes for soil testing.*



*Plate 10—Menard Pressuremeter assembled, showing volumeter, gas supply to apply pressure to the water, probes and connecting conduit.*

An indication of the amount of information available is given in the following list:

	Tested at Materials Research Division 1/1/68 - 31/12/73	Tested at Regional Divisions 1/1/69 - 31/12/73	Total
Graded materials for pavements	15,775	14,541	30,316
Aggregates for bituminous surfacing	2,190	14,914	17,104
Mechanical properties of rock	2,414	0	2,414
Compaction tests	3,163	1,637	4,800
Field density tests	30,374	13,146	43,510
Pavement investigations	319	713	1,032
Pavement deflections	539	84	623
Asphalt mix design	1,701	0	1,701
Asphalt test cylinders	4,103	0	4,103
Paint	597	0	597
Bitumen, cutback bitumen, tars, etc.	4,419	0	4,419
Tension tests on steel	1,739	0	1,739

There is a wide diversity of information available from the data bank and the following list gives an indication of the usage of this data bank (in almost every case the information could otherwise have been obtained only by laborious manual searching and hand listing):

- statistics of materials used on a length of duplication work on the Hume Highway,
- pavement materials used in Bairnsdale Division (to assist a search by a geologist for new sources of these materials),
- grading values of wet-mix FCR and CR from a specific quarry (to produce evidence of the supplier's ability to meet proposed new specifications),
- Texas Ball Mill values for Wimmera sandstone,
- Texas Ball Mill values for stone from about 20 sources (to assist in producing a criterion for TBM values for materials),
- Los Angeles Test results of stone from a particular quarry (to aid assessment prior to purchase of aggregate),
- groupings of stone according to seven ranges of Los Angeles Test values (to assist in preparing new specifications),
- grading values of concrete sands (to assist in the assessment of existing supplies),
- properties of concrete sands (to assist in the formulation of new specifications),
- all hardness test results applicable to sealing aggregates (to enable the issue of a list of all suitable sources),
- quantities of oversize and undersize in one-sized aggregates (to assist in the possible variation of specifications),
- properties of gravels (to assist in assessment as shouldering materials),
- the number of pavement deflection tests done in Bairnsdale Division,
- values for structural grade, deformed, reinforcing bar.

In the future more sophisticated computer facilities, possibly including the use of on-line terminals, will assist rapid retrieval of stored information. This will result in much greater use of the wealth of test data built up over the years.

#### CORROSION OF GALVANIZED CORRUGATED STEEL CULVERTS

For many years engineers have questioned the degree to which galvanized corrugated steel culverts are susceptible to corrosion by air — water — soil environments. In the past, the Board has predicted the potential corrosiveness of soil and water by use of the California Division of Highways Test Method 643-C. However, doubts concerning the applicability of that method to conditions in Victoria led to the establishment of a research project to investigate the occurrence of corrosion in existing steel culverts throughout the State. Field inspections and laboratory testing of samples from culvert locations were done during 1973 and the final report on the project was submitted early in 1974.

Pipes and arches are the two main types of corrugated metal culvert in use today. These are fabricated from steel at least 3.2 mm ( $\frac{1}{8}$  in.) thick and galvanized on both sides. A special aluminium-alloy plate has been used for 10 years in the U.S.A. for culvert fabrication and very good performance has been reported; however, no aluminium-alloy culverts have yet been used in Victoria.

The detailed inspection of galvanized steel culverts at 115 locations involved checking for corrosion on both the inside (exposed to air and water) and the outside (exposed to soil) of the installation, together with sampling of soil and on-site testing of stream-water. The equipment used is shown in Plate 11. Wherever possible, testing at each culvert site consisted of the following steps:

- (i) Measurements were made of the length and diameter of the culvert and the height of soil cover, for possible use in evaluating design procedures.
- (ii) The interior was examined for corrosion. It was found that corrosion had occurred only in the areas affected by the stream-water in the lower half of the structure, i.e. the invert



of pipes. Inspection of these areas involved chipping off the rusty scale with a geological pick, followed by a visual estimation of the loss of metal.

- (iii) When pipe culverts were carrying water, this was tested for pH (a measure of acidity) and electrical conductivity, and the test results were compared with the estimated corrosive loss to see if any correlation was evident.
- (iv) Where possible, every culvert was inspected with the ultrasonic thickness meter to determine whether any thinning of the wall had occurred as a result of soil corrosion. After calibration of the digital scale by use of the stepped calibration block, the probe was applied to smooth surfaces at a number of points within the structure and the readings were noted. This instrument was admirably suited for this application because of its compactness and readability. Its major drawback was that the probe could only be coupled effectively to relatively smooth surfaces. Thus it could not be used to measure corrosion losses in the invert of the pipe, which was usually covered by a crusty, rusty scale.
- (v) Using the electric drill equipped with a hole-saw, a portion of metal was removed from the wall of each accessible culvert. A sample of fill material was removed from the hole so produced and the metal specimen and the soil sample were returned to the laboratory for testing. The holes were patched with concrete.
- (vi) Photographs were taken at each location to assist in later evaluation of the data.

In the laboratory, soil samples were dried and tested for pH and minimum resistivity (which is related to the soluble salt content). After cleaning, the metal specimens were examined for signs of soil corrosion and the remaining thickness of galvanizing was measured.

Several important conclusions were drawn after analysis of all the data:

- (i) There was no correlation between soil and water properties and the observed corrosion.
- (ii) Corrosion caused by soil was not found to be a significant problem in any of the inspected culverts.
- (iii) The corrosion observed was restricted to the areas affected by the stream-water.
- (iv) It was noted that some protection against corrosion can be afforded by coating the inverts of culvert pipes internally with bitumen, or by asphalt paving.
- (v) In the few cases where corrosion had resulted in perforation of the invert, there was no evidence of any deleterious effect on the ability of the structure to support the fill. It was consequently suggested that, in future, when corrosion had occurred to a significant extent, sufficient maintenance could consist of placement of a layer of concrete in the bottom of a pipe so as to prevent erosion.

### 3. ASPHALT DIVISION

#### EXTENT OF WORK

Table 10 shows that 2942 miles of all types of bituminous surfacing work was completed in 1973/74, compared with 3242 miles in 1972/73.



Plate 11—Portable equipment used in tests of corrosion of galvanized metal culverts, and some sample metal specimens obtained.



In 1973/74 the length of sealed pavement on the Board's declared system was increased by 68 miles and the length on unclassified roads by 417 miles as shown in Table 11.

Reconstruction of existing sealed pavements and the restoration of the seal coat amounted to 281 miles of the declared system, 2.1% of the sealed length compared with 2.4% in 1972/73 and 2.8% in 1971/72.

Retreatment on declared roads amounted to 879 miles, or 6.6% of the sealed length, compared with 6.7% in 1972/73.

#### TYPES OF WORK

Sprayed work (initial treatments and retreatments) was again the principal type of work, amounting to 97.1% of the total length of the work.

The plant mix work completed in 1973/74 was 82 miles, i.e. 3% of the total mileage and 6.2% of the total area. The 1973/74 expenditure on plant mix work was equivalent to 28% of the total expenditure on bituminous surfacing. For the plant mix work a total of 230,420 tons was supplied and spread by contractors.

**TABLE 10—BITUMINOUS SURFACING WORK COMPLETED**

Category of Road and Plant Used	1972/73	1973/74
	Miles	Miles
Work on roads to which the Board contributed funds:		
(a) C.R.B. declared roads:		
(i) Board's plant	1458	1241
(ii) Municipal plant	81	81
(iii) Contractors' plant	236	240
	1775	1562
(b) Unclassified roads:		
(i) Board's plant	1115	1039
(ii) Municipal plant	142	128
(iii) Contractors' plant	118	116
	1375	1283
Sub-totals	3150	2845
Work done for other Authorities by the Board's plant (no Board contributions for these works)		
(i) Municipalities	80	84
(ii) State instrumentalities	12	13
(iii) Commonwealth works	—	—
	92	97
<b>Totals</b>	3242	2942

**TABLE 11—BITUMINOUS SURFACING WORK ON VARIOUS ROAD CATEGORIES**

(On roads to which the Board contributed funds during 1973/74)

Type of Work	State Highways	Freeways	Tourists' and Forest Roads	Main Roads	Total Board's Declared System	Unclassified Roads	Totals
	Miles	Miles	Miles	Miles	Miles	Miles	Miles
Initial Treatments:							
Extensions to sealed system—							
(a) Sprayed work	1.30	14.03	11.99	32.34	59.66	413.76	473.42
(b) Plant mix work	—	8.31	—	—	8.31	3.03	11.34
Reconstruction of lengths of previously sealed pavements—							
(a) Sprayed work	105.53	5.74	8.52	152.18	271.97	108.28	380.25
(b) Plant mix work	2.97	—	—	5.67	8.64	13.45	22.09
Widening of existing sealed pavements—							
(a) Sprayed work	26.54	9.57	1.46	56.68	94.25	57.19	151.44
(b) Plant mix work	3.40	2.35	—	—	5.75	1.07	6.82
Duplication of existing sealed pavements—							
(a) Sprayed work	3.71	—	—	3.68	7.39	0.30	7.69
(b) Plant mix work	0.77	—	—	2.36	3.13	1.70	4.83
Final seal—							
(a) Sprayed work	84.97	38.47	10.50	82.47	216.41	103.17	319.58
(b) Plant mix work	0.68	4.79	—	2.42	7.89	4.08	11.97
Retreatments:							
(a) Sprayed work	367.10	27.88	22.80	442.63	860.41	570.04	1430.45
(b) Plant mix work	6.75	0.04	0.03	11.30	18.12	6.70	24.82
<b>Totals</b>	603.72	111.18	55.30	791.73	1561.93	1282.77	2844.70

## COSTS OF WORK

The average unit costs for sprayed work done by the Board's 17 bituminous surfacing units are shown in Table 12. The average overall cost of all types of sprayed work was 29 cents per sq yd compared with 26.5 cents in 1972/73, an increase of 9%. The average cost per ton for asphalt supplied and placed was \$15.04, compared with \$13.82 in 1972/73.

**TABLE 12—AVERAGE COSTS OF SPRAYED BITUMINOUS SURFACING DONE BY C.R.B. PLANT**

(On roads to which the Board contributed funds during 1973/74)  
(Costs in cents per square yard)

Square Yards Costed	NATURE OF WORK																				
	I.T.P. & S. ½ in. & Over		I.T.P. & S. ¼ in.		I.T.P. & S. ⅓ in.		I.T.P. & S. ¼ in. & Sand		Primerseals		Two-application Seals		I.T.S.O. & Reseals ½ in. & Over		I.T.S.O. & Reseals ¼ in.		I.T.S.O. & Reseals ⅓ in.		I.T.S.O. & Reseals ¼ in. & Sand		
	Cents	%	Cents	%	Cents	%	Cents	%	Cents	%	Cents	%	Cents	%	Cents	%	Cents	%	Cents	%	Cents
	7,200		1,490,958		1,177,782		71,689		1,575,921		3,734		14,000		1,872,528		6,622,161		7,743,338		
Material	23.2	61.6	22.2	46.5	20.9	50.9	23.9	56.6	13.2	46.0	21.6	41.0	18.9	53.4	18.4	51.0	14.5	50.7	11.2	52.1	
Stores	0.7	1.8	1.6	3.4	1.4	3.4	1.5	3.6	1.1	3.8	0.9	1.7	1.1	3.1	1.2	3.3	1.0	3.5	0.8	3.7	
Plant hire	5.1	13.5	8.5	17.8	6.8	16.5	5.4	12.8	5.1	17.8	9.0	17.1	5.8	16.4	5.9	16.3	4.6	16.1	3.4	15.8	
Labour	8.7	23.1	15.4	32.3	12.0	29.2	11.4	27.0	9.3	32.4	21.2	40.2	9.6	27.1	10.6	29.4	8.5	29.7	6.1	28.4	
Totals	37.8	100.0	47.7	100.0	41.1	100.0	42.2	100.0	28.7	100.0	52.7	100.0	35.4	100.0	36.1	100.0	28.6	100.0	21.5	100.0	

I.T.P. & S. indicates "Initial Treatment Prime & Seal".  
I.T.S.O. indicates "Initial Treatment Seal Only".

## MATERIALS

### (i) Aggregate

The total quantity of covering aggregate used was approximately 272,000 cu yd on sprayed work done by the Board's plant and 60,300 cu yd on sprayed work done by municipalities and contractors. Table 13 sets out the average prices of aggregates over the last five years and shows that the average price in 1973/74 was \$0.19 per cu yd higher than the average price in 1972/73.

**TABLE 13—AVERAGE PRICE OF AGGREGATE FOR BITUMINOUS SURFACING**

(In roadside stacks)

Material	Prices per cubic yard				
	1969/70	1970/71	1971/72	1972/73	1973/74
	\$	\$	\$	\$	\$
Screenings	5.12	5.08	5.15	5.36	5.65
Gravel	4.61	4.86	4.97	5.17	4.99
Sand	2.82	2.32	1.57	2.02	2.81
Scoria	2.90	3.30	3.41	3.90	3.43
Average price all aggregates	4.93	4.93	5.00	5.22	5.41

### (ii) Bitumen

The Board purchased 26,143 tons of bitumen by contract with four marketing companies.

The bitumen was produced from Kuwait crude oil.

### (iii) Experimental Work

The 1972/73 Report referred to trials conducted in conjunction with the Australian Road Research Board for the purpose of evaluating the relative performance of paving bitumens. In February 1974, a further trial was conducted, involving a reseal on the Hume Highway north of Violet Town between mileages 107.80 and 108.25. A ½ in. one-size (O.S.) altered mudstone aggregate and Class R90 bitumens of different "vispen" index values were used.

The aim of the trial, as in the case of the same type of 1973 trials, was to determine if Class R90 bitumen with a low "vispen" index can be used successfully for sprayed sealing work in hot weather. Information relating to the long term service performance of this bitumen will also be obtained.

The reseal was completed satisfactorily and no initial problems occurred. At 30th June 1974 the surface of each section was in very good order. Future periodical inspections will be made and sampling and testing will be done.

Since 1965/66 the Board has used bitumen produced from Kuwait crude oil. The 1973/74 crisis regarding the supply of Middle East crude oil indicated the possibility of difficulties with the future supply of Kuwait crude oil, and the following trials have accordingly been conducted using bitumen produced from other crude oils:

- (a) a final seal was applied (February 1974) to the Hamilton Highway east of Berrybank between mileages 48.0 and 51.4, using a  $\frac{1}{2}$  in. O.S. basalt aggregate and bitumen produced from Qatar Marine crude oil,
- (b) a reseal was applied (February 1974) on the Warburton Highway near Launching Place between mileages 39.99 and 40.90, using a  $\frac{3}{8}$  in. O.S. toscanite aggregate and bitumen produced from Qatar Marine crude oil,
- (c) a reseal was applied (April 1974) to the northern carriageway of North Road in the City of Caulfield for a distance of 1,300 ft east from Tyrone Street, using a  $\frac{3}{8}$  in. O.S. newer basalt aggregate and bitumen produced from Saudi Arabian crude oil, and
- (d) a reseal was applied (February-March 1974) to the Hume Highway north of Violet Town between mileages 108.25 and 108.57, using a  $\frac{1}{2}$  in. O.S. altered mudstone aggregate and bitumen produced from:
  - (i) Qatar Marine crude oil (mileage 108.25 to 108.39) and
  - (ii) Saudi Arabian crude oil (mileage 108.39 to 108.57).

No initial problems were experienced and all seals were in good condition at 30th June 1974.

During 1973/74, special cutback bitumen primerbinders were used in trials in Warrnambool Division. The purpose of the trials was to compare the life of various primerbinders applied at varying application rates to different pavements and covered with scoria and quartz porphyry aggregates. The trials were as follows:

- (a) A primerseal was applied (December 1973) to the Woolsthorpe-Heywood Road in the Shire of Minhamite, west of Woolsthorpe, on a volcanic tuff pavement. The cover aggregate was  $\frac{1}{4}$  in. O.S. scoria; and
- (b) a primerseal was applied (January 1974) to the Hensley Park Road near Hamilton in the Shire of Dundas, on a gravel pavement. The cover aggregate was  $\frac{1}{4}$  in. O.S. quartz porphyry.

All trial sections were in good condition at 30th June 1974. Regular inspections will be made and testing done over the next two years.

Rubberised asphalt was used in a trial to determine whether reflection cracking in the asphalt surfacing of a Portland cement pavement could be reduced. The Geelong bound carriageway of the Princes Highway West was resurfaced (June 1974) between mileages 42.95 and 43.21 near Cowies Creek, Norlane, with a  $1\frac{1}{2}$  in. nominal depth of  $\frac{1}{2}$  in. nominal size (N.S.) asphalt incorporating 4% by weight of rubber. The Portland cement pavement had been surfaced with 1 in. nominal depth of asphalt in 1965 and severe cracking and spalling of the asphalt at the concrete joints had occurred. This was repaired prior to the trial. A section with  $\frac{1}{2}$  in. N.S. asphalt (without rubber) was also placed as part of the trial.

## SAFETY

In 1973/74 the number of lost time injuries fell from the 355 recorded in 1972/73 to 315, which was just above the 1971/72 figure of 314. The details are shown in Table 14.

**TABLE 14—INJURIES TO BOARD'S EMPLOYEES**

	1972/73	1973/74	Changes from 1972/73	
			Decrease	Increase
Back strains	59	55	4	—
Burns and scalds	27	26	1	—
Burns to eyes	8	13	—	5
Fatal injuries	0	0	—	—
Foreign bodies in eyes	32	23	9	—
Fractures	20	28	—	8
Head injuries	20	22	—	2
Lacerations and wounds	59	55	4	—
Miscellaneous	45	30	15	—
Multiple injuries	0	0	—	—
Occupational diseases	27	17	10	—
Sprains and strains	58	46	12	—
<b>Totals</b>	<b>355</b>	<b>315</b>	<b>55</b>	<b>15</b>



As shown in the tabulation below, the trends in the accident frequency rate and in days lost per million manhours worked, remained fairly stationary, after allowance for the effects of fatal accidents, each of which is assessed in accordance with Australian Standard CZ6—1966 as being equivalent to 6,000 days lost.

	1969/70	1970/71	1971/72	1972/73	1973/74
Total manhours worked	8,757,000	8,966,000	9,077,000	9,050,000	8,756,000
Lost time accidents	369	294	314	355	315
Accident frequency rate/million manhours	42.1	32.7	34.6	39.2	36.0
Days lost	2,058	*7,794	2,113	2,051	1,998
Days lost/million manhours	235	869	233	226	228

\* Includes one or more fatal accidents.

## PUBLICATIONS

In connection with the Board's engineering work, the following papers by Board's officers were presented or published during 1973/74:

Paper	Author
<i>The Quarry Industry in the 1980s—An Economist's View</i> Presented and published in Proceedings of the Annual Conference of the Institute of Quarrying, Australian Division, October 1973.	K. Bush, B. Com.
<i>Cement Modified Crushed Rock</i> Published in Proceedings of the XIVth World Congress — Permanent International Association of Road Congresses, Prague, 1971.	D. T. Currie, B.C.E., Ph.D., M.I.E. Aust.
<i>Experience with some Bitumen Treated Pavement Materials in Australia</i> Presented to the VIIth World Meeting of the International Road Federation, Munich, October 1973.	D. T. Currie, B.C.E., Ph.D., M.I.E. Aust. and R. H. Bowering, B.Sc.(Eng.), M.I.C.E., M.I.E. Aust., Chief Bitumen Engineer, Mobil Oil Australia Ltd.
<i>Ultrasonic Testing of Welds Using AWS D1.1-72</i> Published in Journal of Testing Instruments and Controls, Vol. 10, No. 8, August 1973.	R. S. Gilmour, B.Sc., A.R.C.S.T., M.I.E. Aust.
<i>Friction Welding Stud Shear Connectors to Steel Beams</i> Published in Metal Construction and British Welding Journal, Vol. 6, No. 5, May 1974.	R. S. Gilmour, B.Sc., A.R.C.S.T., M.I.E. Aust.
<i>A Fracture Mechanics Approach to the Stress Corrosion Susceptibility of Pre-stressing Tendons</i> Presented to the Third Tewkesbury Symposium, Melbourne, June 1974.	R. S. Gilmour, B.Sc., A.R.C.S.T., M.I.E. Aust. and A. L. Walker, B.App.Sc.
<i>Current Status of Penetration Testing in Australia</i> Presented as a State-of-the-Art Report on Penetration Testing in Australia, to the European Symposium on Penetration Testing, Stockholm, 1974.	J. C. Holden, Dip.C.E., B.E. (Civil), M.Eng.Sc., Ph.D., M.I.E. Aust., A.M.A.S.C.E.
<i>An Experimental Study of Temperatures in a Box Girder Bridge</i> Delivered at the Fourth Australasian Conference on the Mechanics of Structures and Materials, University of Queensland, August 1973.	A. G. Lanigan, B.E., Ph.D. and A. H. Bryant, B.E., Ph.D., Senior Lecturer, Department of Civil Engineering, University of Auckland, N.Z.
<i>Some Aspects of Urban Planning</i> Presented to a joint meeting of the Transportation and Highways Branch and the Environmental Branch, Victoria Division, The Institution of Engineers, Australia, August 1973.	R. S. Mathews, B.Surv., Dip. R. & T.P., C.T.P. & C., M.R.A.P.I., M.I.S. (Aust.), and I. R. Thomson, B.A., and K. Bush, B. Com.
<i>Design, Instrumentation and Construction of a Continuously Reinforced Concrete Road Pavement.</i> Presented at The Institution of Engineers, Australia, Symposium on Concrete Research and Development, 1970-73, Sydney, September 1973.	B. R. Munce, Dip.Mech.E., M.I.E. Aust., and R. B. Russell, B.Sc., and M. D. Meadley.
<i>Surfacing of Orthotropic Steel Decked Bridges</i> Report on overseas mission for the Lower Yarra Crossing Authority, August-September 1973.	B. L. Phillips, Dip.C.E., M.I.E. Aust.
<i>The Testing of Road Marking Paints</i> Published in Proceedings of XIVth World Congress—Permanent International Association of Road Congresses, Prague, 1971.	H. D. Taskis, B.Sc., Dip.Ed.
<i>Some Aspects of Motorway Design</i> Published in Traffic Engineering and Control, October 1973.	R. T. Underwood, M.E., B.C.E., Dip. T. & R.P., C.H.T.(Yale), C.E., F.I.T.E., M.R.A.P.I., F.Inst. H.E., M.I.E. Aust.
<i>Some Aspects of the Design of Urban Freeways</i> Published in MEMO No. 13, March 1974.	R. T. Underwood, M.E., B.C.E., Dip. T. & R.P., C.H.T.(Yale), C.E., F.I.T.E., M.R.A.P.I., F.Inst. H.E., M.I.E. Aust.

Other publications were:

Engineering Note No. 102, Additives to Crushed Rock,  
Engineering Note No. 103, Repair of a Wide, Shallow Depression in a Concrete Pavement,  
Engineering Note No. 104, Influence of Grading upon Sand Equivalent,  
Engineering Note No. 105, The Use of Adhesives,  
Engineering Note No. 106, Coaxial Cable Relocation,  
Engineering Note No. 107, Painting of Guide Posts.

Research Memorandum No. 16, March 1972, "A Comparison of the Results of the Washington Degradation Test with the Determination of the Clay Mineral Content of Aggregates, using X-ray Diffractometry and Thermal Balance", by J. R. Webber, B.E.(Civil), Dip. T. & R.P., M.I.E. Aust., submitted in partial fulfilment of the requirements for the Degree of Master of Engineering Science in Highway Engineering, School of Highway Engineering, University of New South Wales, and

Research Memorandum No. 17, June 1973, "Road Rating Survey 1971: Analysis of Results", by J. N. Hanks, B.Sc., S.C. Servais, B.Ec., and K. I. York, A.R.M.I.T. (App. Phys.).

Research Memorandum No. 18, June, 1974, "Assessment of a Troxler Nuclear Hydrodensimeter", by R. J. Chalmers, B.E.(Civil).

## STAFF

During 1973/74 Mr. F. W. Docking, Divisional Engineer, Dandenong, and Mr. W. H. Dolamore, Divisional Engineer, Bairnsdale, retired. Both of these officers had served with the Board for 47 years and made valuable contributions to the work of the Board during that period.

The untimely deaths of Mr. A. E. Pollard, Assistant Right-of-Way Engineer, and Mr. F. Hopwood were recorded during the year.

The total cost of work performed by the Board in 1973/74 on its direct works and for other authorities, and by municipalities with funds provided by the Board, was \$100,573,000. At 30th June 1974 the total staff of the Chief Engineer's Branch was 1416.

I thank the staff of the Branch for their continued loyal and diligent service to the Board.

W. S. BRAKE, B.C.E., C.E., C.T.P. & C., M.I.E. Aust.  
Chief Engineer.

